

FROM THE PRESIDENT

When you make your call to Action from the jobsite to place an order, we know you need that item *now*. So we'll do everything we can to get the order right and get it right to you as soon as possible.

That's *our* call to Action.

And since 1980, we've enjoyed steady growth due to this dogged determination to provide the very best customer service and speedy delivery of all orders—with 98% of them going out the same day the call came in. Little wonder why, today, Action Industries is one of the nation's leading distributors of garage door weatherseals, hardware, accessories and now we've added a complete line of fasteners.

Of course, our excellent Just-In-Time service would be nothing without our unmatched range of products. Every year, there are plenty more we add to our stock, as you'll see in this catalog. In fact, new product development is also a cornerstone of Action Industries, with two of our best-selling items having actually been developed right here.

Of course, if you don't find exactly what you need, call and tell us exactly what you're looking for—we're more than pleased (and experienced!) to provide you with the engineering assistance you need and a custom-made order with no minimums required.

If you'd like to learn more, just call us at 216-252-7800.

Everyone here looks forward to serving you.

Sincerely,



Patrick Marron
President
Action Industries



WEATHERSEALS | 4-25



FASTENERS | 26-33



ACCESSORIES | 34-49

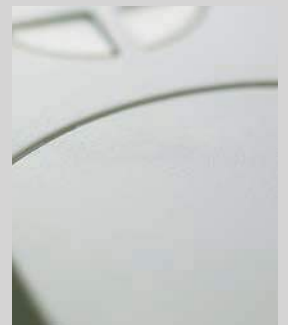

DOOR HARDWARE | 50-64



Weatherseals



NEW FOR 2007

The reasons to call Action just keep growing. Over the past few months, we've been busy stocking our warehouse with over 200 new items. From weatherseals, brushes, aluminum retainers and dock kits to clip-on guide seals, hardware, control accessories and—now—even a full line of cable and fastener products.

So along with the great advice you've always counted on us for, you can enjoy great value on just about every product you need to do any project right—including the one you're working on today.



CUSTOM DESIGN ENGINEERING CAPABILITIES



If you need help with an engineering challenge of any kind, we can help. Our engineering department has the ability to respond quickly to design inquiries and prototype requests—big or small, complex or simple—sometimes in a matter of days.

Whether you supply the actual prototype or just a design idea, we can create the drawing, make the tooling, and send back samples, while developing a streamlined production process to meet budgetary constraints. We are interested in both long and short run products.

Call your salesperson to discuss your immediate or future products needs.

CUSTOM EXTRUSION CAPABILITIES



Action can create custom plastic extrusion and fabrication for your particular application needs. And our goal is to produce a correct part on the first run.

Specializing in close tolerance intricate extrusions as well as tubing, rods, and strips of engineered thermoplastic resins, our production capabilities and know-how insures you receive the proper profile to your exact specifications.

Our tooling is designed and manufactured in-house, which will save time and money for your company. Routine maintenance on the tooling insures quality for the life of your extrusion program.

PLASTIC EXTRUSIONS CAN BE RUN USING A VARIETY OF MATERIALS INCLUDING:

PVC
POLYCARBONATES
LOW AND HIGH DENSITY POLYETHYLENE
POLYPROPYLENE
THERMO PLASTIC ELASTOMER (TPE)

CUSTOM FABRICATION PROCESSES AND SECONDARY OPERATIONS INCLUDE:

PUNCHING
NOTCHING
DRILLING
ASSEMBLY
PLASTIC WELDING
TAPE APPLICATIONS
CUSTOM PACKAGING REQUIREMENTS

TABLE OF CONTENTS

Standard Aluminum Retainers	4
VHB Tape.....	5
Standard Rolling Steel Door Clip-On Guide Seal.....	5
Standard Brush Seals.....	5
Standard Zebra Brush™ Seals.....	5
High Visibility Warning Tape.....	6
Standard Vinyl Seals.....	6
Standard Rubber Seals	6
Large Aluminum Retainers	7
Reversible Vinyl Insert Seals.....	8
Large Brush Seals.....	8
Large Rubber Seal.....	8
Slim-Line Aluminum Retainers.....	8
V Channel Slim-Line Seal.....	9
Slim-Line Clip-On Guide Seal.....	9
Slim-Line Vinyl Seals	9
Slim-Line Bulb Seals	9
Slim-Line Brush Seals	10
Aluminum Bottom Seal Retainers.....	10-11
Ship-lap/Tongue & Groove Adapters	11
Plastic Vinyl Bottom Seal	11
Plastic Bottom Seal Retainers	12
Bottom “T” Rubber Seals	12
Bottom “T” Vinyl Seals	13
Bottom “Bead” End Vinyl Seals.....	13
Bottom “T” Bulb Vinyl Seals.....	13
Wood Door Bottom “Nail-On” Seals	14
”P” and “D” Seals	14
Rigid Flexible T&G and Shiplap Top Seal.....	14
Flexible Top Seal	14
Flexible Vinyl Reverse Angle Jamb Seals	15
Flexible TPR Reverse Angle Jamb Seals.....	15
Rigid Vinyl Reverse Angle Jamb Seals.....	15
Excaliber.....	16
Storm Shield® Garage Door Threshold.....	17
Stop Guards™ Parking Wedges.....	18
Parking Zone Detector.....	18
Dock Leveler Seals.....	26
Passage Door Perimeter Seal Kits.....	20
Passage Door Sweep Seal Kits.....	21
Rubber Sheeting.....	22
Rolling Steel Door Bottom Seal	22
Vinyl Strip Doors.....	23-24
Wheel Chocks	25
Laminated Dock Bumpers	25



Weatherseals



STANDARD ALUMINUM RETAINERS

Made of high strength aluminum ore and are designed to hold any 1/2" to 3" brush or vinyl seal from our standard line.

STOCK LENGTHS: 8'-2", 10'-2", 12'-2", 14'-2", 16'-2", 18'-2"

PART NO.	0-299'	300'-899'	900'-1999'	2000'
2" OFFSET				
Mill	A0083-MI-W	Call	Call	Call
Bronze	A0083-BR-W	Call	Call	Call
White	A0083-WH-W	Call	Call	Call
3" OFFSET				
Mill	A0086-MI-W	Call	Call	Call
2" STR				
Mill	A0288-MI-W	Call	Call	Call
Bronze	A0288-BR-W	Call	Call	Call
White	A0288-WH-W	Call	Call	Call
2" 45°				
Mill	A0282-MI-W	Call	Call	Call
Bronze	A0282-BR-W	Call	Call	Call
White	A0282-WH-W	Call	Call	Call
2" OFFSET				
Mill	A0084-MI-W	Call	Call	Call
1" STR				
Mill	A0088-MI-W	Call	Call	Call
Bronze	A0088-BR-W	Call	Call	Call
White	A0088-WH-W	Call	Call	Call
Punched	A0088-PU-W	Call	Call	Call
1" 45°				
Mill	A0082-MI-W	Call	Call	Call
Bronze	A0082-BR-W	Call	Call	Call
White	A0082-WH-W	Call	Call	Call
1" 90°				
Mill	A0087-MI-W	Call	Call	Call
1" R 45°				
Mill	A0085-MI-W	Call	Call	Call

USED AS JAMB SEALS

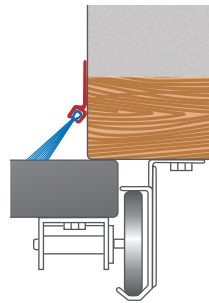

A0082-MI-W/B0768-00-W
(1" STANDARD BRUSH SEAL, PG.5)

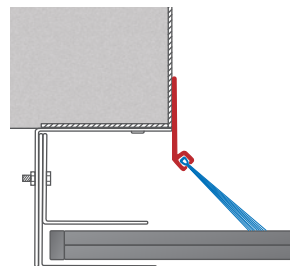

A0282-MI-W/B0772-00-W
(3" STANDARD BRUSH SEAL, PG.5)

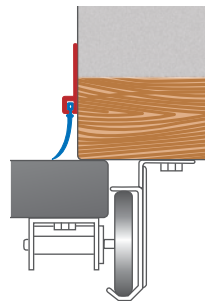

A0088-MI-W/V0031-GR-W
(1 3/8" VINYL SEAL, PG.6)

USED AS HEADER SEALS

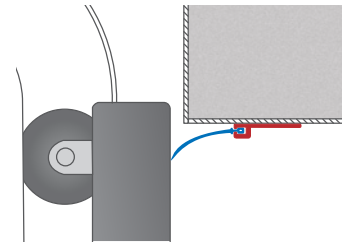

A0088-MI-WV0031-GR-W
(1 3/8" VINYL SEAL, PG.6)

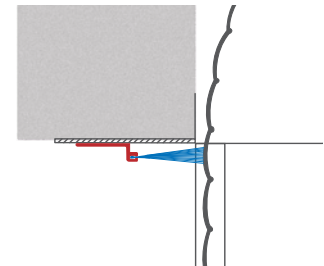

A0083-MI-W/B0772-00-W
(3" STANDARD BRUSH SEAL, PG.5)

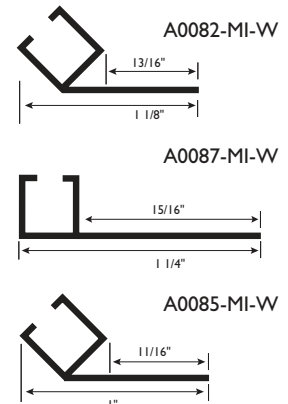
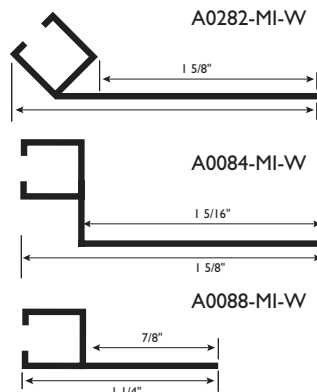
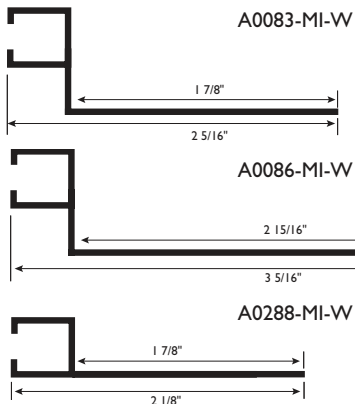

VHB TAPE

Made of conformable foam and may be used in place of mechanical fasteners. VHB Tape can be applied in temperatures as low as 32° F and is temperature resistant up to 300° F.

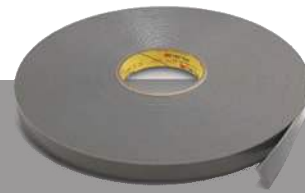

PART NO.	COLOR	ROLL SIZE	1-5'	6+
Z0000-00-Z	Grey	3/4" x 36 yds.	Call	Call
Z0001-00-Z	Grey	1" x 36 yds.	Call	Call

STANDARD ROLLING STEEL DOOR CLIP-ON GUIDE SEAL

Made of a rigid plastic which is designed to clip on to guides up to 1/4" thick. Its versatility enables you to insert any standard brush or vinyl.

STOCK LENGTHS: 8'-2", 10'-2", 12'-2", 14'-2", 16'-2", 18'-2"

PART NO.	COLOR	0-299'	300'-899'	900'-1999'	2000'+
PL035-00-W	Grey	Call	Call	Call	Call

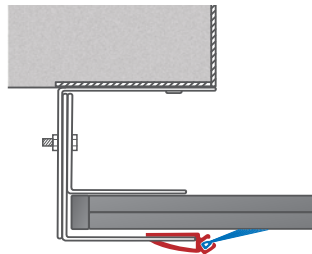

PL035-0-W/B0771-00-W
(STANDARD BRUSH SEAL, SEE BELOW)

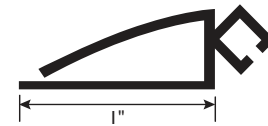

STANDARD AND ZEBRA BRUSH SEALS

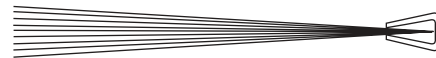

Both our Standard and Zebra Brush™ seals are made of versatile and long-lasting filaments that will not hold water or freeze at sub-zero temperatures. Bristles are wrapped around a steel rod to prevent 'pull-out'. Fits all standard aluminum retainers or standard rolling steel clip-on retainer.

STOCK LENGTHS: 6', 7', 8', 9', 10'

STANDARD BRUSH SEAL					
BRISTLE LENGTH	PART NO.	0-299'	300'-899'	900'-1999'	2000'+
3"	B0772-00-W	Call	Call	Call	Call
2"	B0771-00-W	Call	Call	Call	Call
1 3/4"	B0770-00-W	Call	Call	Call	Call
1 1/2"	B0769-00-W	Call	Call	Call	Call
1"	B0768-00-W	Call	Call	Call	Call
3/4"	B0767-00-W	Call	Call	Call	Call
1/2"	B0766-00-W	Call	Call	Call	Call

STANDARD ZEBRA SEAL					
BRISTLE LENGTH	PART NO.	0-299'	300'-899'	900'-1999'	2000'+
3"	B0772-ZB-W	Call	Call	Call	Call
2"	B0771-ZB-W	Call	Call	Call	Call
1"	B0768-ZB-W	Call	Call	Call	Call





HIGH VISIBILITY WARNING TAPE



PART NO.	SIZE	1-4	5-9	10-19	20+
ST100-00-Z	3" x 36 Yds.	Call	Call	Call	Call

STANDARD VINYL SEALS

These seals possess excellent memory for shape retention under various conditions at a reasonable cost. Designed to fit in our standard aluminum retainers or standard rolling steel clip-on retainer.



AVAILABLE IN ROLLS OR INSTALLED

PART NO.	0-299'	300'-899'	900'-1999'	2000'
----------	--------	-----------	------------	-------

1" (ALSO AVAILABLE IN 750' ROLLS)

Grey	V0021-GR-W	Call	Call	Call	Call
Bronze	V0022-BR-W	Call	Call	Call	Call
White	V0023-WH-W	Call	Call	Call	Call
Sandstone	V0020-SS-W	Call	Call	Call	Call

1 3/8" (ALSO AVAILABLE IN 500' ROLLS)

Grey	V0031-GR-W	Call	Call	Call	Call
Bronze	V0032-BR-W	Call	Call	Call	Call
White	V0033-WH-W	Call	Call	Call	Call
Sandstone	V0030-SS-W	Call	Call	Call	Call
Cherry	V0032-CH-W	Call	Call	Call	Call
Black	V0034-BL-W	Call	Call	Call	Call

2" (ALSO AVAILABLE IN 400' ROLLS)

Grey	V0041-GR-W	Call	Call	Call	Call
Bronze	V0042-BR-W	Call	Call	Call	Call
White	V0043-WH-W	Call	Call	Call	Call
Sandstone	V0040-SS-W	Call	Call	Call	Call

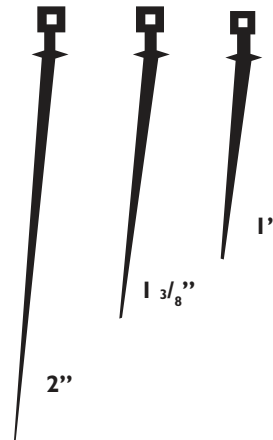

STANDARD RUBBER SEALS

Designed for applications where extreme temperature changes (-50°-350°F) may occur.

AVAILABLE IN ROLLS OR INSTALLED

SIZE	COLOR	PART NO.	0-299'	300'-899'	900'-1999'	2000'+
1 3/8"	Black	V0036-00-W	Call	Call	Call	Call
2 1/2"	Black	V0056-00-W	Call	Call	Call	Call



REVERSIBLE VINYL INSERT SEAL

Cut a 1/8" wide saw kerf into any wood, plastic or composite moulding. Press the vinyl into the groove for a clean, custom look. No nails or glue needed.



PART NO. 0-299' 300'-899' 900'-1999' 2000'

1" STOP MOULD VINYL INSERT SEAL

	PART NO.	0-299'	300'-899'	900'-1999'	2000'
Grey	V0061-GR-W	Call	Call	Call	Call
Brown	V0062-BR-W	Call	Call	Call	Call
White	V0063-WH-W	Call	Call	Call	Call
Sandstone	V0057-SD-W	Call	Call	Call	Call
Cherry	V0059-CH-W	Call	Call	Call	Call

LARGE ALUMINUM RETAINERS

For oversized applications such as rolling steel and hangar doors or for situations where excessive gaps occur. They are designed to accommodate our dense, oversized large brush seals.

STOCK LENGTHS: 8'-2", 10'-2", 12'-2", 14'-2", 16'-2", 18'-2"
FINISH: MILL



SIZE	PART NO.	0-299'	300'-899'	900'-1999'	2000'+
5 1/2" STR	A7089-MI-W	Call	Call	Call	Call
5 1/2" 45°	A7092-MI-W	Call	Call	Call	Call
2" OFFSET	A7083-MI-W	Call	Call	Call	Call
3" OFFSET	A7086-MI-W	Call	Call	Call	Call
1" 45°	A7082-MI-W	Call	Call	Call	Call
1" 90°	A7087-MI-W	Call	Call	Call	Call
1" STR	A7088-MI-W	Call	Call	Call	Call
3" STR	A7388-MI-W	Call	Call	Call	Call
3" 45°	A7382-MI-W	Call	Call	Call	Call

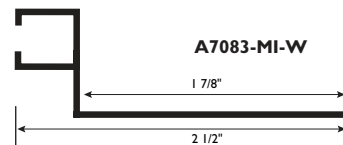
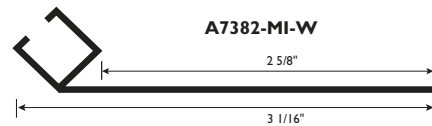
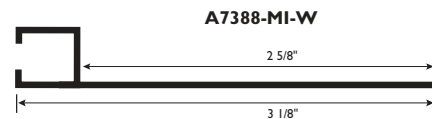
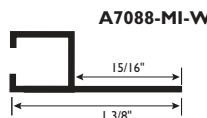
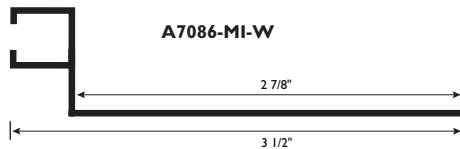
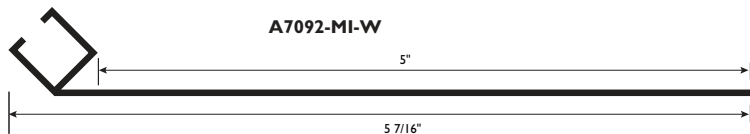
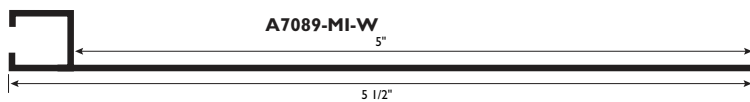



LARGE BRUSH SEALS

Oversized polypropylene brushes are designed to fit our large channel aluminum retainers and possess the same high-quality properties as our standard brushes.



STOCK LENGTHS: 6', 7', 8', 9', 10'



BRISTLE LENGTH	PART NO.	0-299'	300'-899'	900'-1999'	2000'+
6"	B3776-00-W	Call	Call	Call	Call
5"	B3775-00-W	Call	Call	Call	Call
4"	B3774-00-W	Call	Call	Call	Call
3"	B3772-00-W	Call	Call	Call	Call
2"	B3771-00-W	Call	Call	Call	Call
1"	B3768-00-W	Call	Call	Call	Call

LARGE RUBBER SEAL

EPDM synthetic rubber insert is specially designed for applications where extreme temperature changes (-50°-350°f) may occur. Designed to fit any of our large aluminum retainers.



3" (ALSO AVAILABLE IN 150' ROLLS)

Black	V7066-00-W	Call	Call	Call	Call
-------	------------	------	------	------	------

SLIM-LINE ALUMINUM RETAINERS

Slightly smaller than our standard aluminum profiles, slim-line is an economical alternative and will accept any slim-line brush or vinyls.



STOCK LENGTHS: 8'-2", 10'-2", 12'-2", 14'-2", 16'-2", 18'-2"

	PART NO.	0-299'	300'-899'	900'-1999'	2000'
7/8" STR					
Mill	A2088-MI-W	Call	Call	Call	Call
Bronze	A2088-BR-W	Call	Call	Call	Call
White	A2088-WH-W	Call	Call	Call	Call
7/8 45°					
Mill	A2082-MI-W	Call	Call	Call	Call
Bronze	A2082-BR-W	Call	Call	Call	Call
White	A2082-WH-W	Call	Call	Call	Call
1/2"					
Mill	A2830-MI-W	Call	Call	Call	Call
Bronze	A2830-BR-W	Call	Call	Call	Call
White	A2830-WH-W	Call	Call	Call	Call

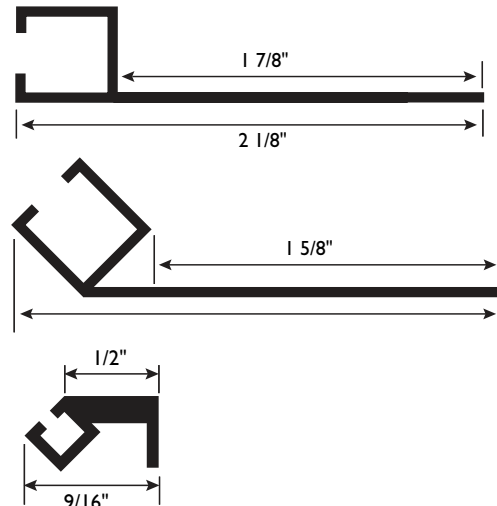

V CHANNEL SLIM-LINE SEAL

Thermo Plastic Rubber (TPR) seals are rugged and flexible.

AVAILABLE IN ROLLS OR INSTALLED.



COLOR	PART NO.	0-299'	300'-899'	900'-1999'	2000'+
Black	PLT53-BL-W	Call	Call	Call	Call

SLIM-LINE CLIP-ON GUIDE SEAL

Action slim-line rigid plastic clip-on retainer will clip on to guides up to 3/16" thick. Its versatility enables you to insert any slim-line brush or vinyl to best suit your application.

STOCK LENGTHS: 8'-2", 10'-2", 12'-2", 14'-2", 16'-2", 18'-2"

COLOR	PART NO.	0-299'	300'-899'	900'-1999'	2000'+
Grey	PL235-GR-W	Call	Call	Call	Call
Bronze	PL235-BR-W	Call	Call	Call	Call
White	PL235-WH-W	Call	Call	Call	Call

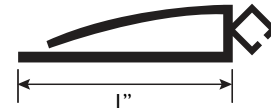

SLIM-LINE VINYL SEALS

Composed from the purest chemical combination, these seals possess excellent memory for shape retention under various conditions at a reasonable cost. Slim-line vinyls are designed to fit in our slim-line aluminum retainers or slim-line clip-on retainers.

AVAILABLE IN ROLLS OR INSTALLED

	PART NO.	0-299'	300'-899'	900'-1999'	2000'
1" (ALSO AVAILABLE IN 750' ROLLS)					
Grey	V2021-GR-W	Call	Call	Call	Call
Bronze	V2022-BR-W	Call	Call	Call	Call
White	V2023-WH-W	Call	Call	Call	Call
Sandstone	V2020-SS-W	Call	Call	Call	Call



SLIM-LINE BULB SEALS

Composed of a soft vinyl compound to compress for an airtight passage door perimeter seal. These bulbs are designed to fit in any slim-line aluminum retainer.

AVAILABLE IN ROLLS OR INSTALLED

	PART NO.	0-299'	300'-899'	900'-1999'	2000'
5/16" (ALSO AVAILABLE IN 750' ROLLS)					
Grey	V2025-GR-W	Call	Call	Call	Call
Bronze	V2025-BR-W	Call	Call	Call	Call
White	V2025-WH-W	Call	Call	Call	Call
Sandstone	V2025-SS-W	Call	Call	Call	Call

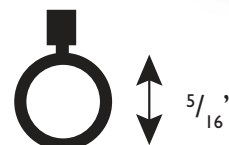



SLIM-LINE BRUSH SEALS

Comparable to our standard brush line, but has a smaller profile. The brush filaments do not hold water and will not freeze at sub-zero temperatures, and make an excellent seal for irregular surfaces. Slim-line brushes coordinate with any of our slim-line aluminum retainers or slim-line plastic clip-on retainers.

STOCK LENGTHS: 6', 7', 8', 9', 10'

BRISTLE LENGTH	PART NO.	0-299'	300'-899'	900'-1999'	2000'+
2"	B2771-00-W	Call	Call	Call	Call
1 1/2"	B2769-00-W	Call	Call	Call	Call
1"	B2768-00-W	Call	Call	Call	Call
3/4"	B2767-00-W	Call	Call	Call	Call
1/2"	B2766-00-W	Call	Call	Call	Call



ALUMINUM BOTTOM SEAL RETAINERS

Designed as a longer lasting, versatile retainer that will accept 1/4" T-style rubber, vinyl or bulb seals.

STOCK LENGTHS: 8'-2", 10'-2", 12'-2", 14'-2", 16'-2", 18'-2"

SIZE	PART NO.	0-299'	300'-899'	900'-1999'	2000'+
1 1/4"	A1250-00-W	Call	Call	Call	Call
1 5/8"	A1700-00-W	Call	Call	Call	Call
1 5/8" x 1/4"	A1703-00-W	Call	Call	Call	Call
1" x 1 1/2"	A1015-01-W	Call	Call	Call	Call
1 3/8 x 1 1/2"	A1315-01-W	Call	Call	Call	Call
1 3/8" x 3"	A1330-01-W	Call	Call	Call	Call
1 3/4" x 1 3/4"	A1818-01-W	Call	Call	Call	Call
1 3/4" x 3"	A1830-01-W	Call	Call	Call	Call
2"	A2000-TG-W	Call	Call	Call	Call
2" X 1 5/8"	A2050-01-W	Call	Call	Call	Call
2" x 2"	A2020-01-W	Call	Call	Call	Call
2" x 2"	A2040-01-W	Call	Call	Call	Call
2" x 3"	A2030-01-W	Call	Call	Call	Call

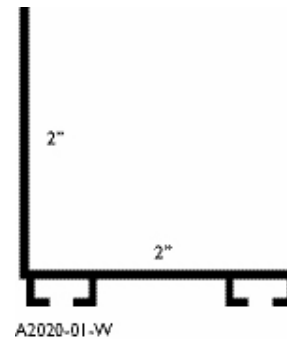
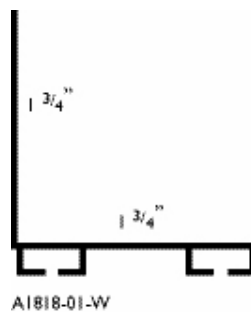
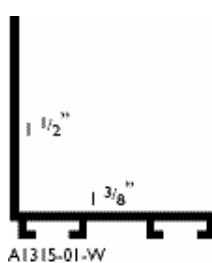
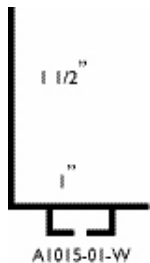
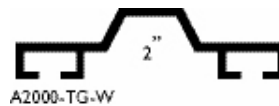
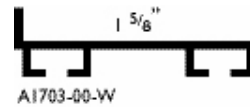
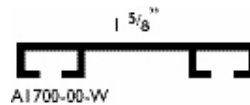
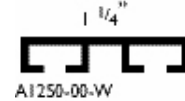

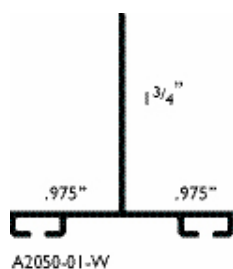
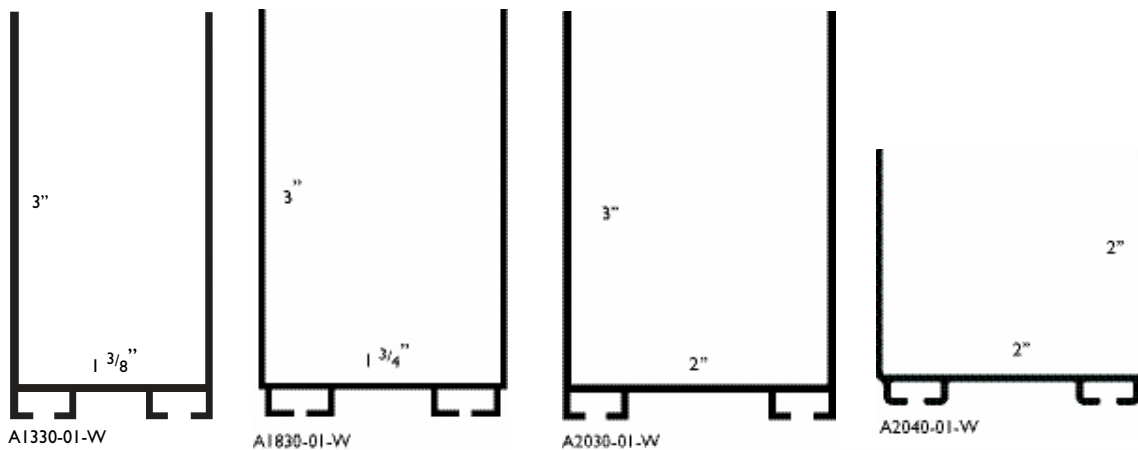

SHIP-LAP/TONGUE AND GROOVE ADAPTERS

Converts tongue and groove sections to ship-lap or ship-lap to tongue and groove. Additionally, A2015-02-W serves dual purpose of being used as either a ship-lap adapter or as a bottom retainer. With each of these innovative accessories, you can make use of the panels available to you.

STOCK LENGTHS: 8'-2", 10'-2", 12'-2", 14'-2", 16'-2", 18'-2"

SIZE	PART NO.	0-299'	300'-899'	900'-1999'	2000'+
2 x 1 1/2"	A2015-01-W	Call	Call	Call	Call
2 x 1 1/2"	A2015-02-W	Call	Call	Call	Call

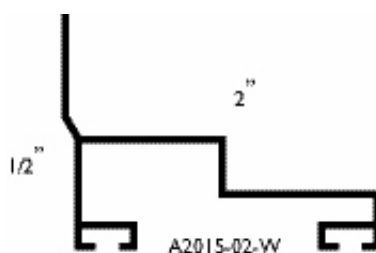
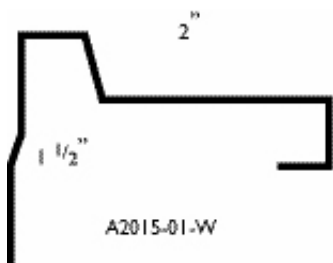

PLASTIC VINYL BOTTOM SEAL

All-in-one design is economical and provides easy, one step field replacement installation with two "contact point" protection.

STOCK LENGTHS: 8'-2", 10'-2", 12'-2", 14'-2", 16'-2", 18'-2"

SIZE	PART NO.	0-299'	300'-899'	900'-1999'	2000'+
2" x 7/8"	PL206-BK-W	Call	Call	Call	Call



Weatherseals



PLASTIC BOTTOM SEAL RETAINERS

Made to withstand cracking and hold their shape in temperature extremes. They are designed as economical and versatile retainers that will accept 1/4" T-style rubber, vinyl or bulb seals.

STOCK LENGTHS: 8'-2", 10'-2", 12'-2", 14'-2", 16'-2", 18'-2"

SIZE	PART NO.	0-299'	300'-899'	900'-1999'	2000'+
1 5/8"	P1700-BK-W	Call	Call	Call	Call
1" x 1 1/2"	P1015-BK-W	Call	Call	Call	Call
1 1/2" x 1 3/8"	P1315-BK-W	Call	Call	Call	Call
1 3/4" x 1 3/4"	P1818-BK-W	Call	Call	Call	Call
2" x 2"	P2020-BK-W	Call	Call	Call	Call

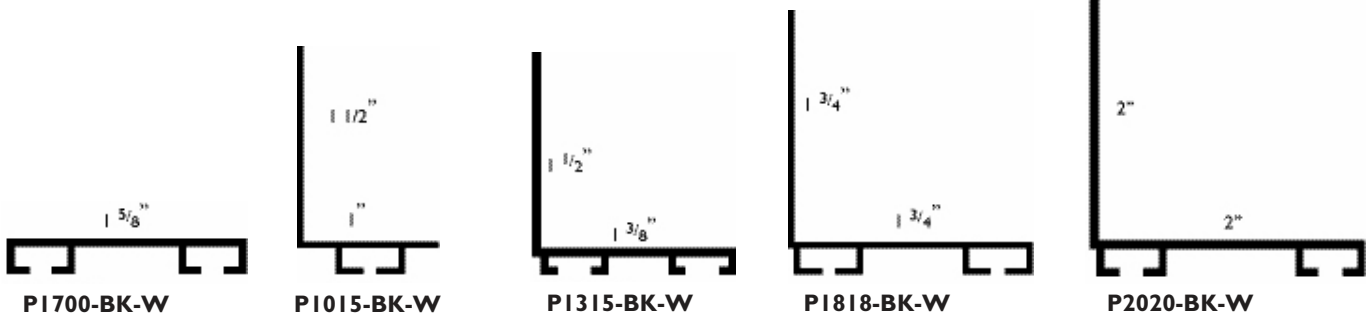

BOTTOM "T" RUBBER SEALS

Made of durable, black EPDM synthetic rubber, excellent in extreme temperature conditions (-50° - 350°). Designed with a 1/4" "T" to fit the popular T-style bottom retainers.

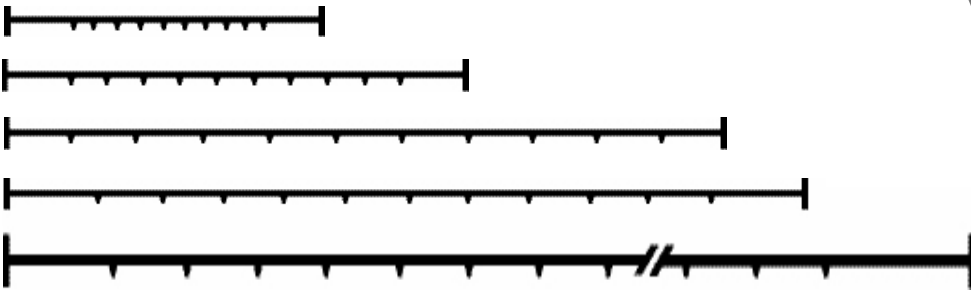
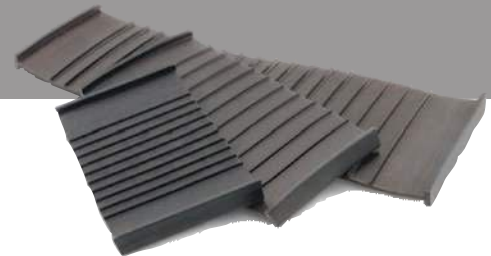

	PART NO.	0-299'	300'-899'	900'-1999'	2000'
3" (ALSO AVAILABLE IN 400' ROLLS)					
Black	T2563-00-W	Call	Call	Call	Call
4" (ALSO AVAILABLE IN 300' ROLLS)					
Black	T2564-00-W	Call	Call	Call	Call
6" (ALSO AVAILABLE IN 200' ROLLS)					
Black	T2566-00-W	Call	Call	Call	Call
7" (ALSO AVAILABLE IN 200' ROLLS)					
Black	T2567-00-W	Call	Call	Call	Call
9" (ALSO AVAILABLE IN 100' ROLLS)					
Black	T2569-00-W	Call	Call	Call	Call

BOTTOM "T" VINYL SEALS

Designed with a 1/4" "T" to fit the popular T-style bottom retainers.



PART NO. 0-299' 300'-899' 900'-1999' 2000'

3" (ALSO AVAILABLE IN 400' ROLLS)

Grey	V2563-00-W	Call	Call	Call	Call
White	V2563-WH-W	Call	Call	Call	Call

4" (ALSO AVAILABLE IN 200' ROLLS)

Grey	V2564-00-W	Call	Call	Call	Call
White	V2564-WH-W	Call	Call	Call	Call
Yellow	V2564-YL-W	Call	Call	Call	Call
Black	V2564-BL-W	Call	Call	Call	Call

6" (ALSO AVAILABLE IN 200' ROLLS)

Grey	V2566-00-W	Call	Call	Call	Call
Black	V2566-BL-W	Call	Call	Call	Call

BOTTOM "BEAD" END VINYL SEALS

This high quality grey vinyl bottom seal is available in 3", 4" & 6" widths, bead diameter 3/16" - 7/32" and is offered in stock 100' rolls or cut to your specifications.

STOCK LENGTHS: 100' ROLLS, 6" AVAILABLE IN 200' ROLLS



SIZE	COLOR	PART NO.	0-299'	300'-899'	900'-1999'	2000'+
1 1/4"	Grey	V3561-GR-W	Call	Call	Call	Call
3"	Grey	V3563-00-W	Call	Call	Call	Call
4"	Grey	V3564-00-W	Call	Call	Call	Call
6"	Grey	V3566-00-W	Call	Call	Call	Call

BOTTOM "T" BULB VINYL SEALS

Made from a strong, grey vinyl compound.
Designed with a 1/4" "T" to fit the popular T-style bottom retainers.

STOCK LENGTHS: 100' ROLLS

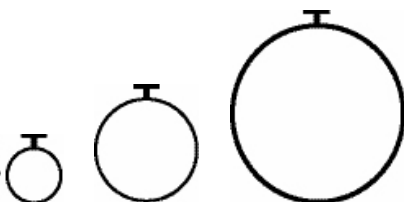

DIAMETER	COLOR	PART NO.	0-299'	300'-899'	900'-1999'	2000'+
1/2"	Grey	V0500-GR-W	Call	Call	Call	Call
1"	Grey	V1000-GR-W	Call	Call	Call	Call
1 1/2"	Grey	V1500-GR-W	Call	Call	Call	Call
1 1/2"	Yellow	V1500-YL-W	Call	Call	Call	Call



WOOD DOOR BOTTOM "NAIL-ON" SEALS

Available in two materials to accommodate customer's preferences. Either our dense EPDM rubber or softer EPDM sponge seals will create an excellent seal on the bottom of wood garage doors.

STOCK LENGTHS: 100' ROLLS



PART NO.	0-299'	300'-899'	900'-1999'	2000'
----------	--------	-----------	------------	-------

1 3/8" (ALSO AVAILABLE IN 100' ROLLS)

	PART NO.	0-299'	300'-899'	900'-1999'	2000'
Dense Rubber	BDR14-00-W	Call	Call	Call	Call
Soft Sponge	BDF14-00-W	Call	Call	Call	Call

"P" AND "D" SEALS

Lengths come with convenient paper-covered adhesive backing.



PART NO.	0-299'	300'-899'	900'-1999'	2000'
----------	--------	-----------	------------	-------

"D" 1000' PER BOX/500' PER ROLL

Black	Z0200-00-W	Call	Call	Call	Call
-------	------------	------	------	------	------

"P" 500' PER BOX/250' PER ROLL

Black	Z0250-00-W	Call	Call	Call	Call
-------	------------	------	------	------	------

RIGID FLEXIBLE T&G AND SHIPLAP TOP SEAL

STOCK LENGTHS: 8'-2", 10'-2", 12'-2", 14'-2", 16'-2", 18'-2"

COLOR	PART NO.	0-299'	300'-899'	900'-1999'	2000'+
Black	PL043-BL-W	Call	Call	Call	Call

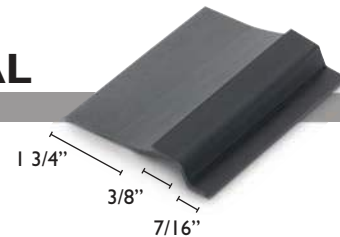

FLEXIBLE TOP SEAL

STOCK LENGTHS: 100' ROLLS

COLOR	PART NO.	0-299'	300'-899'	900'-1999'	2000'+
Black	PL053-BL-W	Call	Call	Call	Call

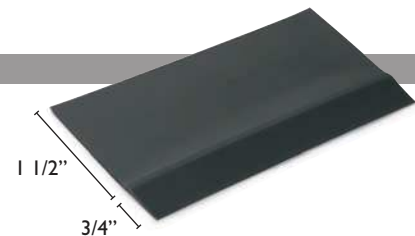

FLEXIBLE VINYL REVERSE ANGLE JAMB SEALS

Designed to withstand cracking and to hold its shape in temperature extremes.

STOCK LENGTHS: 100' ROLLS

COLOR	PART NO.	0-299'	300'-899'	900'-1999'	2000'+
GREY	PL030-GR-W	Call	Call	Call	Call
WHITE	PL031-WH-W	Call	Call	Call	Call
BROWN	PL032-BR-W	Call	Call	Call	Call
BLACK	PL033-BL-W	Call	Call	Call	Call

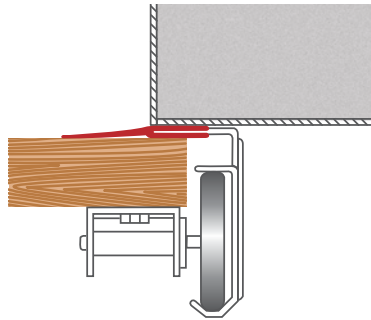
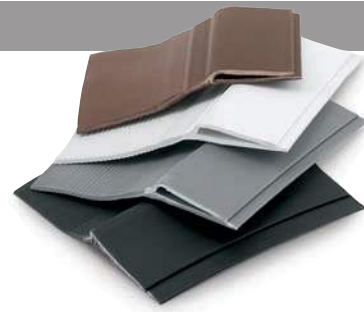

FLEXIBLE TPR REVERSE ANGLE JAMB SEALS

Designed for supreme flexibility and durability. TPR withstands tearing and cracking, holds its shape and gives superior performance in temperature extremes ranging from -60° to 160°. Coiled for convenience.

STOCK LENGTHS: 100' ROLLS

COLOR	PART NO.	0-299'	300'-899'	900'-1999'	2000'+
GREY	PLT30-GR-W	Call	Call	Call	Call
WHITE	PLT31-WH-W	Call	Call	Call	Call
BROWN	PLT32-BR-W	Call	Call	Call	Call
BLACK	PLT33-BL-W	Call	Call	Call	Call

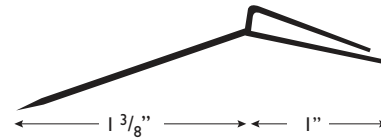

RIGID VINYL REVERSE ANGLE JAMB SEALS

Designed to withstand cracking and to hold its shape in temperature extremes. Available in rigid lengths.

STOCK LENGTHS:
8'-2", 10'-2", 12'-2", 14'-2", 16'-2", 18'-2"

COLOR	PART NO.	0-299'	300'-899'	900'-1999'	2000'+
GREY	PLR30-GR-W	Call	Call	Call	Call
WHITE	PLR31-WH-W	Call	Call	Call	Call
BROWN	PLR32-BR-W	Call	Call	Call	Call
BLACK	PLR33-BL-W	Call	Call	Call	Call

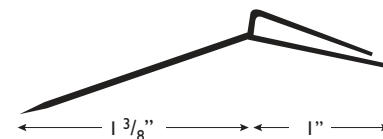



EXCALIBUR™ SOLID ALUMINUM THRESHOLD

For industrial overhead and entry door applications where maximum strength and durability are required, the patented design stands 1/2" tall and is built with 6061-T6 aluminum to withstand extreme weight and excessive traffic conditions.

Two-way fastening/seal system won't shift, buckle or leak, while top V-groove design for skid proof protection and improved tire traction on loading docks and incline ramps.

The 1/2" diameter wire access port makes it easy for sensor and security installations. Kit comes complete with pre-drilled countersink holes, 3/8" anchors and sealant.



Excalibur™ heavy duty aluminum thresholds are made of 6061-T6 aluminum and come in six standard lengths up to 20'4" with either 4" or 6" widths. Sold on its own with pre-drilled counter sink holes, 3/8" anchors and adhesive.

4" WIDTH	A9004-MI-W	1-10	10-20	21+
8' Length		Call	Call	Call
10' Length		Call	Call	Call
12' Length		Call	Call	Call
16' Length		Call	Call	Call
18' Length		Call	Call	Call
20' Length		Call	Call	Call
6" WIDTH	A9006-MI-W	1-10	10-20	21+
8' Length		Call	Call	Call
10' Length		Call	Call	Call
12' Length		Call	Call	Call
16' Length		Call	Call	Call
18' Length		Call	Call	Call
20' Length		Call	Call	Call



STORM SHIELD®

THE ORIGINAL GARAGE DOOR THRESHOLD

ONLY FROM ACTION INDUSTRIES



Storm Shield will block wind-driven rain, snow, dirt, sand and leaves to help reduce rust a moisture damage to tools and stored valuables and help reduce costly concrete repairs. Also works to keep more heat in to reduce energy costs, while keeping more rodents out.

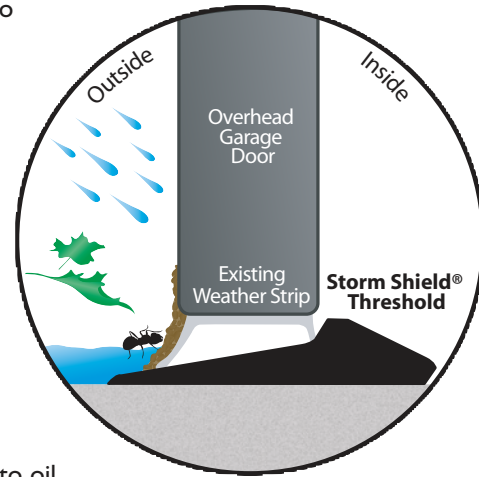
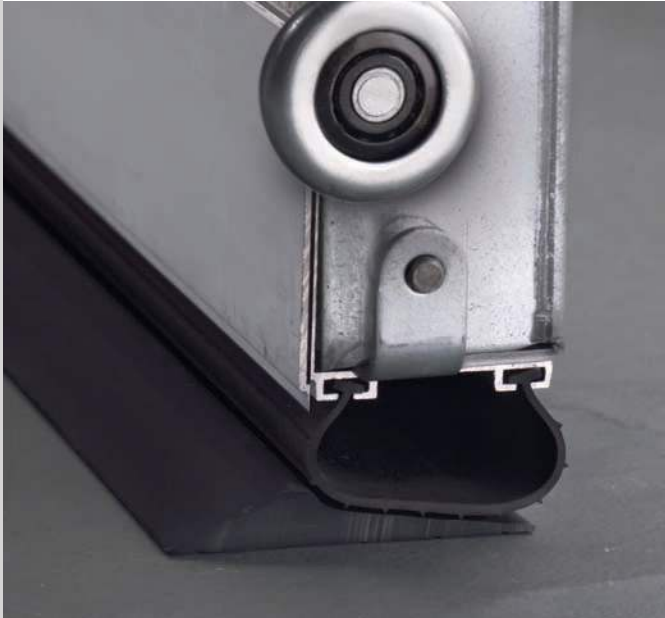

Will not crack or shatter, is resistant to oil, gas, anti-freeze and other chemical substances, remains flexible from -40 F to 150 F, and meets California Fire Marshall and CPAI-84 requirements for flame resistance. Comes prepackaged with adhesive and a full 2-year warranty.

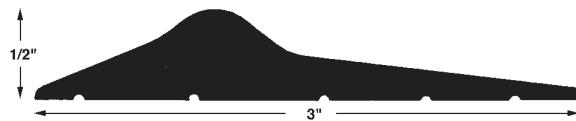

STANDARD KIT PRICING

Prices include 6 oz. squeeze tube adhesives.

	10'	16'	18'	20'
1-19 KITS	Call	Call	Call	Call
20-40 KITS	Call	Call	Call	Call
40+ KITS	Call	Call	Call	Call

SPECIAL BULK PRICING

Price per foot includes adhesive. One 6 oz. squeeze tube per 10', or one 10.3 oz. caulk tube per 17' provided.

0-99'	100'-299'	300'-899'	900'-1999'	2000'+
Call	Call	Call	Call	Call

SHOWROOM BROCHURES

Increase your profits with this glossy, 2-color brochure! Receive twenty-five free brochures with every 100' bulk roll of Storm Shield® or with every case order – simply by asking!





STOP GUARDS™

TAKE THE GUESSWORK OUT OF PARKING IN A GARAGE!

Action's Stop Guards™ are the perfect solution to offer your customers for preventing vehicle and property damage in their garage. Stop Guards™ Helps prevent damage to garage or carport due to miscalculations when parking, while making sure autos are pulled in far enough so the garage door doesn't hit them when it closes.



Will not crack or shatter, is resistant to oil, gas, anti-freeze and other chemical substances, remains flexible from -40 F to 150 F, and meets California Fire Marshall and CPAI-84 requirements for flame resistance. Comes prepackaged with adhesive and a full 2-year warranty.

STANDARD KIT PRICING: Kit pricing includes (2) 12" Parking Wedges & (1) 6 oz. tube adhesive for installation.

PART NO.	1-4	5-9	10-19	20+
SG100-00-A	Call	Call	Call	Call

10' Parking Wedge (adhesive sold separately)

PART NO.	1-4	5-9	10-19	20+
SGR00-00-Y	Call	Call	Call	Call

ADHESIVE

6 oz Adhesive Squeeze Tube Covers 10'	Call
10.3 oz Adhesive Caulk Tube Covers 17'	Call

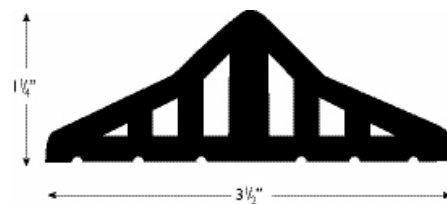

PARKING ZONE DETECTOR

An innovative precision-parking device, providing solutions for depth perception and overcrowding in the home environment. The green light illuminates when the garage is entered, turns amber midway, and red when it's time to stop.

PART NO.	1-4	5-9	10-19	20+
SPZ15-00-Z	Call	Call	Call	Call

DON'T FORGET YOUR SHOWROOM BROCHURES

Increase your profits with this glossy, 2-color brochure! Receive twenty-five FREE brochures with every six Stop Guards™ ordered – simply by asking!





DOCK LEVELER SEAL KITS

Pre-packaged kits are designed with a heavy galvanized channel for quick weld installation to help eliminate drafts, dirt and pests from getting in while keeping debris from falling into the pit. (Making it excellent for the food industry).

Each kit contains two 8' pieces each of the galvanized channel, our standard 1" 90 aluminum retainer and an insertion component to meet your specification.



PART NO.	SEAL STYLE	0-299'	300'-899'	900'-1999'	2000'+
DSK10-21-A	1" vinyl	Call	Call	Call	Call
DSK10-31-A	1 3/8" vinyl	Call	Call	Call	Call
DSK10-41-A	2" vinyl	Call	Call	Call	Call
DSK10-36-A	1 3/8" EPDM rubber	Call	Call	Call	Call
DSK10-56-A	2 1/2" EPDM rubber	Call	Call	Call	Call
DSK10-66-A	1/2" brush	Call	Call	Call	Call
DSK10-67-A	3/4" brush	Call	Call	Call	Call
DSK10-68-A	1" brush	Call	Call	Call	Call
DSK10-69-A	1 1/2" brush	Call	Call	Call	Call
DSK10-70-A	1 3/4" brush	Call	Call	Call	Call
DSK10-71-A	2" brush	Call	Call	Call	Call
DSK10-72-A	3" brush	Call	Call	Call	Call
DSK1Z-68-A	1" Zebra Brush™	Call	Call	Call	Call
DSK1Z-71-A	2" Zebra Brush™	Call	Call	Call	Call
DSK1Z-72-A	3" Zebra Brush™	Call	Call	Call	Call
DSK00-08-W	8' galvanized retainer	Call	Call	Call	Call
DLF10-01-W	Rear Foam Seal Kit	Call	Call	Call	Call
DLFSB-00-W	1" Dia. Foam	Call	Call	Call	Call
DLRBS-00-W	8' Spiral Poly Twisted Brush Seal	Call	Call	Call	Call
DLSSR-08-W	3/16" x 8' Steel Rod	Call	Call	Call	Call



DSK10-21-A



DSK10-36-A



DSK10-68-A

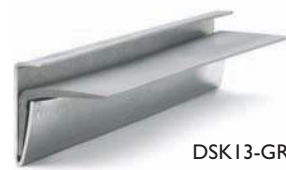

DSK13-GR-W



DSK12-68-A



DLF10-01-W



DLRBS-00-W



PASSAGE DOOR PERIMETER SEAL KITS

Kits are a combination of our Slim-line brush or vinyl bulb and aluminum retainers. Each packaged kit comes complete with matching screws and pre-punched retainers for quick installation. Available for 3' x 7', 4' x 7' or 6' x 7' doors.



COMMERCIAL AND RESIDENTIAL

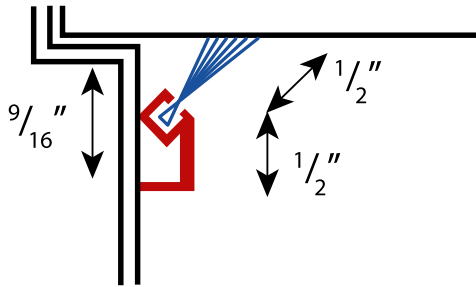

		PART NO.	1-4	5-9	10-19	20+
3' X 7'						
Mill	J17MI-00-A	Call	Call	Call	Call	Call
Bronze	J17BR-00-A	Call	Call	Call	Call	Call
White	J17WH-00-A	Call	Call	Call	Call	Call
4' X 7'						
Mill	J18MI-00-A	Call	Call	Call	Call	Call
Bronze	J18BR-00-A	Call	Call	Call	Call	Call
White	J18WH-00-A	Call	Call	Call	Call	Call
6' X 7'						
Mill	J20MI-00-A	Call	Call	Call	Call	Call
Bronze	J20BR-00-A	Call	Call	Call	Call	Call
White	J20WH-00-A	Call	Call	Call	Call	Call

		PART NO.	1-4	5-9	10-19	20+
3' X 7'						
Mill	V17MI-00-A	Call	Call	Call	Call	Call
Bronze	V17BR-00-A	Call	Call	Call	Call	Call
White	V17WH-00-A	Call	Call	Call	Call	Call
4' X 7'						
Mill	V18MI-00-A	Call	Call	Call	Call	Call
Bronze	V18BR-00-A	Call	Call	Call	Call	Call
White	V18WH-00-A	Call	Call	Call	Call	Call
6' X 7'						
Mill	V20MI-00-A	Call	Call	Call	Call	Call
Bronze	V20BR-00-A	Call	Call	Call	Call	Call
White	V20WH-00-A	Call	Call	Call	Call	Call

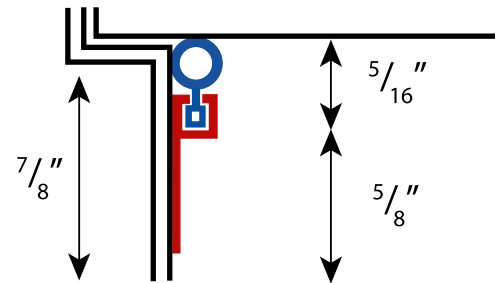



PASSAGE DOOR SWEEP SEAL KITS

Action passage door sweep seal kits are a combination of our quality brush or vinyl and aluminum retainers. Each packaged kit comes complete with matching screws and pre-punched retainers for quick installation. Available in mill, brown or white for 3' or 4' doors.



COMMERCIAL STANDARD SWEEP KIT

PART NO.		1-4	5-9	10-19	20+
3'					
Mill	S3BCO-MI-A	Call	Call	Call	Call
Bronze	S3BCO-BR-A	Call	Call	Call	Call
White	S3BCO-WH-A	Call	Call	Call	Call
4'					
Mill	S4BCO-MI-A	Call	Call	Call	Call
Bronze	S4BCO-BR-A	Call	Call	Call	Call
White	S4BCO-WH-A	Call	Call	Call	Call

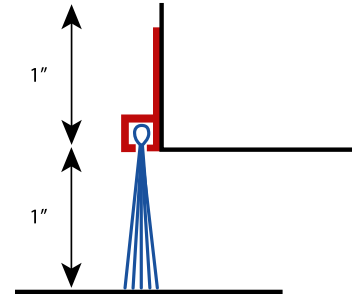

COMMERCIAL STANDARD SEAL KIT

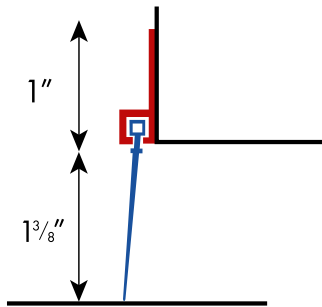

PART NO.		1-4	5-9	10-19	20+
3'					
Mill	S3VCO-MI-A	Call	Call	Call	Call
Bronze	S3VCO-BR-A	Call	Call	Call	Call
White	S3VCO-WH-A	Call	Call	Call	Call
4'					
Mill	S4VCO-MI-A	Call	Call	Call	Call
Bronze	S4VCO-BR-A	Call	Call	Call	Call
White	S4VCO-WH-A	Call	Call	Call	Call

RESIDENTIAL SLIMLINE SWEEP KIT

PART NO.		1-4	5-9	10-19	20+
3'					
Mill	S3BRE-MI-A	Call	Call	Call	Call
Bronze	S3BRE-BR-A	Call	Call	Call	Call
White	S3BRE-WH-A	Call	Call	Call	Call
4'					
Mill	S4BRE-MI-A	Call	Call	Call	Call
Bronze	S4BRE-BR-A	Call	Call	Call	Call
White	S4BRE-WH-A	Call	Call	Call	Call

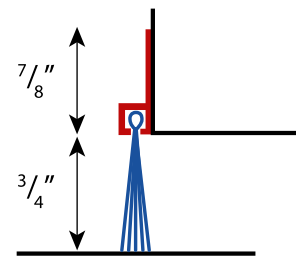

RESIDENTIAL SLIMLINE SEAL KIT

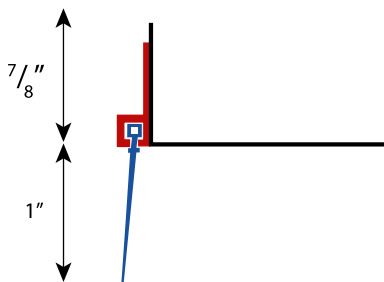

PART NO.		1-4	5-9	10-19	20+
3'					
Mill	S3VRE-MI-A	Call	Call	Call	Call
Bronze	S3VRE-BR-A	Call	Call	Call	Call
White	S3VRE-WH-A	Call	Call	Call	Call
4'					
Mill	S4VRE-MI-A	Call	Call	Call	Call
Bronze	S4VRE-BR-A	Call	Call	Call	Call
White	S4VRE-WH-A	Call	Call	Call	Call



RUBBER SHEETING

Universal reinforced and non-reinforced black neoprene rubber sheeting for applications such as header baffles and airport hangar doors. Partial rolls available.



1/16" X 50' THICKNESS NON-REINFORCED

ROLL WIDTH	PART NO.	0-99'	100'-299'	300'-899'	900'-1999'
6"	R116N-06-W	Call	Call	Call	Call
9"	R116N-09-W	Call	Call	Call	Call
12"	R116N-12-W	Call	Call	Call	Call
18"	R116N-18-W	Call	Call	Call	Call

1/8" X 50' THICKNESS NON-REINFORCED

ROLL WIDTH	PART NO.	0-99'	100'-299'	300'-899'	900'-1999'
6"	R018N-06-W	Call	Call	Call	Call
9"	R018N-09-W	Call	Call	Call	Call
12"	R018N-12-W	Call	Call	Call	Call
18"	R018N-18-W	Call	Call	Call	Call

1/8" X 50' THICKNESS SINGLE REINFORCED

ROLL WIDTH	PART NO.	0-99'	100'-299'	300'-899'	900'-1999'
6"	R018R-06-W	Call	Call	Call	Call
9"	R018R-09-W	Call	Call	Call	Call
12"	R018R-12-W	Call	Call	Call	Call
18"	R018R-18-W	Call	Call	Call	Call

3/16" X 33' THICKNESS TRIPLE REINFORCED

ROLL WIDTH	PART NO.	0-99'	100'-299'	300'-899'	900'-1999'
6"	R316R-06-W	Call	Call	Call	Call
9"	R316R-09-W	Call	Call	Call	Call
12"	R316R-12-W	Call	Call	Call	Call
18"	R316R-18-W	Call	Call	Call	Call

ROLLING STEEL DOOR BOTTOM SEAL

Made of a durable, black EPDM synthetic rubber. This long-lasting seal bolts between the bottom bars on rolling steel doors, and is an efficient one-piece installation. This seal is designed for applications where extreme temperatures changes (-50°-350°F) may occur. Also accepts pneumatic reversing hoses.

STOCK LENGTHS: 100' ROLLS

PART NO.	0-299'	300'-899'	900'-1999'	2000'+
BDS13-00-W	Call	Call	Call	Call

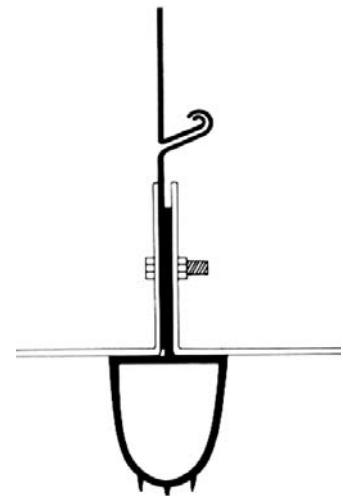

VERILON® VINYL STRIP WEATHERSEALS

All three types of Verilon® Vinyl Strips are UV stabilized to prevent yellowing and are resistant to most inorganic acids, bases and salts. Plus, they are all GSA approved for federal government purchase.

CALL YOUR SALES REPRESENTATIVE FOR PRICING.

STANDARD STRIP

Available in four thicknesses and widths to meet the needs of light-duty to heavy-duty applications, indoors and outdoors, with an operating temperature of -10F to 140F.

LOW TEMPERATURE STRIP

Specially fabricated with FDA approved ingredients for use by the food processing industry, this strip helps sustain sub-zero temperatures while remaining flexible from -50F to 140F. This is the only Verilon Vinyl Strip for freezer use.

WELDING STRIP

For welding booths as well as spraying, grinding and sand blasting enclosures, this strip is fire retardant, highly transparent, noise deadening and prevents near UV and UV radiation from penetrating adjacent areas—blocking over 99% of UV radiation. Meets California Fire Marshall and CPAI-84 requirements for flame resistance (sparks won't burn through), though it is not intended as a substitute for approved eye protection, which should always be worn.

Available in 80-gauge thickness and 8" width in Bronze, Veri-Orange and Blue, or 120-gauge thickness and 12" width in Bronze. Available in flat only.



USE THE RECOMMENDATIONS BELOW TO HELP YOU DETERMINE PROPER GAUGE, WIDTH AND OVERLAP.

	THICKNESS	WIDTH	OVERLAP
For lightweight traffic closures only, such as conveyor doors (not for exterior openings).	.060"	6"	Full (3")
For freezers, coolers, refrigerated trucks, and personnel doors.	.080"	8"	2"
For interior doors to 10' high. Not recommended for exterior opening.	.080"	8"	Full (4")
For minimum protection for interior/exterior openings from 9' to 14' high.	.120"	12"	4"
For better protection for interior/exterior openings from 9' to 14' high, severe temperature and windy conditions.	.120"	12"	Full (6")
For exterior doors up to 25' high with heavy vehicular traffic.	.160"	16"	4"
For exterior doors up to 25' high with constant heavy-duty equipment traffic. Best for sound control. Not recommended for frequent personnel traffic.	.160"	16"	Full (8")



STANDARD STRIP DOORS WITH MOUNTING HARDWARE

PART NO.	DOOR OPENING WxH	STRIP WIDTH AND THICKNESS	% OF OVERAP	WEIGHT	PRICE
W0407-08-Z	4' x 7'	8" x .080"	50%	25 lbs	Call
W0408-08-Z	4' x 8'	8" x .080"	50%	26 lbs	Call
W0608-08-Z	6' x 8'	8" x .080"	50%	42 lbs	Call
W0808-08-Z	8' x 8'	8" x .080"	50%	52 lbs	Call
W0808-12-Z	8' x 8'	12" x .120"	66%	98 lbs	Call
W0810-08-Z	8' x 10'	8" x .080"	50%	64 lbs	Call
W0810-12-Z	8' x 10'	12" x .120"	66%	102 lbs	Call
W0910-12-Z	9' x 10'	12" x .120"	66%	127 lbs	Call
W01010-08-Z	10' x 10'	8" x .080"	50%	75 lbs	Call
W1010-12-Z	10' x 10'	12" x .120"	66%	134 lbs	Call
W1212-12-Z	12' x 12'	12" x .120"	66%	174 lbs	Call

CUSTOM STRIP DOORS WITH MOUNTING HARDWARE

PARTIAL OVERLAP		FULL OVERLAP	
STRIP WIDTH AND THICKNESS	PRICE PER SQ/FT	STRIP WIDTH AND THICKNESS	PRICE PER SQ/FT
8" x .080"	Call	8" x .080"	Call
12" x .120"	Call	12" x .120"	Call
16" x .160"	Call	16" x .160"	Call

*CUSTOM STRIP DOORS ARE NON-RETURNABLE.

BULK STRIP DOORS MATERIAL

STRIP WIDTH AND THICKNESS	ROLL SIZE	PRICE PER SQ/FT
6" x .060"	100'	Call
6" x .060"	300'	Call
8" x .080"	300'	Call
12" x .120"	200'	Call
16" x .160"	100'	Call



VINCL-00-Z
Vinyl Door Cleaner and
Preserver 15 oz can

NEW UNIVERSAL MOUNT HARDWARE

FOR FAST INSTALLATION TO EITHER HEADER OR WALL

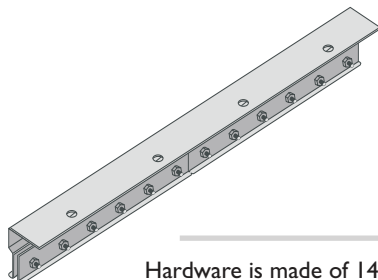

Hardware is made of 14 gauge galvanized steel with mounting bolts pre-studded in the bracket

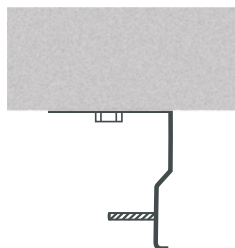

Header Mount bolts inside the door frame to the door header (lintel)

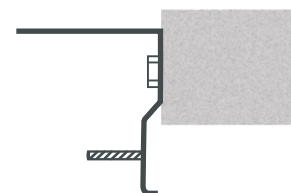

Wall Mount bolts to wall



WHEEL CHOCKS



MOLDED RUBBER WHEEL CHOCKS WITH EYE BOLT

Another option for your toughest circumstances. These rubber chocks are impregnated with nylon to give you the best skid protection possible in bad weather. 6"H x 10"W x 8"L Weighs 9lbs.

PART NO: LWR00-00-Z



ALUMINUM WHEEL CHOCKS

The other end of the spectrum: when a lightweight, yet durable solution is called for. These chocks are cast of a high grade aluminum alloy and will do the job nicely. 7 3/4"H x 8 1/2"W x 12"L. Weighs 5lbs.

PART NO: LWA00-00-Z



ORANGE URETHANE WHEEL CHOCKS

Eye-catching orange for safety - stands out! This wheel chock's contoured shape grips both tire and pavement. Provides heavy-duty performance. 8"H x 8 1/2"W x 12"L. Weighs 5 lbs.

PART NO: LWU00-00-Z



LAMINATED WHEEL CHOCKS

Tire layers are compressed and bolted between two 1/4" steel plates. They're a perfect match for your most adverse conditions. 8"H x 8"W x 8"L. Weighs 14 lbs

PART NO: LWL00-00-Z

WHEEL CHOCKS ACCESSORIES

5' Wheel chock security chain with attachment links

LWX05-00-Z

15' Wheel chock security chain with attachment links

LWX15-00-Z

LAMINATED DOCK BUMPERS

Our laminated dock bumpers are the answer when vehicle damage to buildings, loading docks and cargo is occurring. Put a stop to it with these heavy-duty bumpers. Each is constructed of tightly sandwiched pads of fabric truck tires, which are shaped and bound by support rods and steel plates or angles. We supply a variety of models.

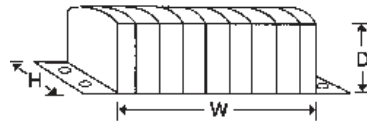
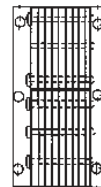

DESCRIPTION	PART NO.	PRICE	WEIGHT
6"d x 10"h x 14"w	L1014-06-Z	Call	33lbs
4"d x 10"h x 36"w	L1036-04-Z	Call	70lbs
6"d x 10"h x 24"w	L1024-06-Z	Call	55lbs
4"d x 10"h x 24"w	L1024-04-Z	Call	46lbs
4"d x 10"h x 14"w	L1014-04-Z	Call	29lbs
4"d x 12"h x 14"w	L1214-04-Z	Call	35lbs
4"d x 12"h x 24"w	L1224-04-Z	Call	58lbs
4"d x 24"h x 11"w	L2411-04-Z	Call	56lbs

