

**RESIDENTIAL & LIGHT COMMERCIAL  
SLIDE GATE OPERATOR WITH BATTERY BACKUP**

# RSL12V



## **DC-POWERED SLIDE GATE OPERATOR WITH BUILT-IN BATTERY BACKUP**

**Our most advanced residential and light commercial pad mounted slide gate operator. Features a powerful DC motor with soft start/stop operation for quiet and reliable performance and rated for gates up to 800 lbs. and 25 ft. in length and cycling up to 120 times per day.**

The RSL also utilizes the Power Management System to provide industry leading power efficiency maximizing cycles when running on battery backup or optional solar power while maintaining optimum battery integrity. LiftMaster® Elite Series™ gate operators offer innovative features to meet a variety of applications and feature a 3 year warranty.

### **On-Board Receiver**



Exclusive from LiftMaster®, a single remote control solution for gate access and additional access points. Ability to add up to 50 remote controls.

**LiftMaster®**  
ELITE SERIES™

# RSL12V

## STANDARD FEATURES

### DC Motor – soft start/stop operation

Reduces the stress and shock to the gate system by slowly ramping up gate speed on open and ramping down gate speed on close. This type of operation promotes longer gate and operator life and quieter operation.

### Battery Backup

Provides complete operation of gate and all DC control devices and sensing devices in the event of power loss. 12V 7AH battery standard, upgrade to 2nd 7AH battery or 33AH battery for extended battery backup.

### Electronic Limit System

Simple-to-set electronic limit system allows limit setting with just the push of a button.

### Electronic Braking System

Innovative brake design keeps brake engaged with or without power when the gate is in closed position. Only open input or selectable auto open feature will override braking system. Operator uses electromotive technology to power brake upon power loss/battery depletion or in solar applications.

### External Manual Disconnect Switch

Simply press manual disconnect switch to push gate open. No need to drop drive chain to manually open gate. Operator retains open/close limit setting when resuming normal operation. No special tools required.



### Inherent Obstruction Sensing

This unit's internal obstruction sensing system offers force adjustment for the open and closed directions. If the gate strikes an obstruction, a closing gate will reverse to open and an opening gate will stop.

### External Obstruction Sensing

To meet UL325 safety standards, secondary entrapment devices must be added. Inputs are provided to simplify adding secondary non-contact or contact sensors such as photo-eyes and edge devices. Installer will be able to recommend best secondary entrapment device for the application.

### Clear Impact Resistant Poly Carbonate Control Box

Cover Allows clear view to key diagnostic LEDs, speeds troubleshooting, and saves time and money. Includes fuse holders.

### Control Inputs

Control inputs allow for the connection of external devices. Accessories include; loop detectors, LiftMaster® photo eyes, free exit probe, wireless access control equipment, and solenoid lock.

### LED Indicators

Operator input, status and diagnostic LEDs simplify setup and troubleshooting.

## SPECIFICATIONS

### Power

110v/60Hz or solar power

### Operator Weight

100 lbs.

### Power

12VDC/500 mA Accessory Power

### UL Listed

UL325 & UL991 Listed Class I & II

### Construction

Gear Reduction:  
10:1 Reducer in synthetic oil bath

### Motor:

Heavy-Duty 12VDC

### Chassis:

Zinc coated steel

### Cover:

UV stabilized cover

### Dimensions

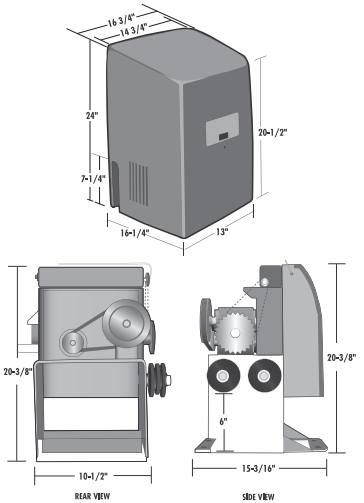

## OPTIONAL FEATURES

### Solar Ready

Operator can be solar powered by adding optional solar panel. Power Management System delivers power when needed most for operating a gate while conserving power at all other times for best solar performance. Solar gate operators and accessories qualify for 30% tax credit through 2016. See [www.liftmaster.com](http://www.liftmaster.com) for more details.

### The Protector System® Safety Sensors 50-220\*\*

Prevents the gate from closing onto people, pets or objects. Includes mounting brackets.

\*\*Only 50-220 photo eyes go into power save mode and minimize powerdraw when gate is not opening

### Recommended Capacities

DC Operator System	MAX GATE WT. (lbs.)	MAX GATE Length (ft.)	Recommended Cycles Per Day
12VDC	800	25	120

### Battery Backup Operation

(16 ft. / 650 lbs. slide gate. Stand alone system)

Battery	Cycles
1 - 7AH	40
2 - 7AH	100
1 - 33AH*	275

Low Power draw safety sensors and accessories recommended for best performance on battery backup

\*33AH battery not available in combination with heater option

Go to [www.liftmaster.com](http://www.liftmaster.com) for full list of accessories

### ADDITIONAL FEATURES

Universal controller with multiple inputs

Timer-to-close: 0-180 seconds

Surge/spike protection

Dual gate compatible

Right- or left-handed operation

Ability to auto-open or failsecure when power fails/battery depletion

Heater model available

### 3-YEAR WARRANTY

# LiftMaster®

THE CHAMBERLAIN GROUP, INC.  
845 Larch Avenue • Elmhurst, IL 60126

[www.liftmaster.com](http://www.liftmaster.com)



I.C./F.C.C. Certified

