

RAYNOR®
STYLEFORM™
SECTIONAL RAISED PANEL DOORS



StyleForm OPTIMA, raised-panel, white, with square windows

S T Y L I S H

R E L I A B L E

D U R A B L E

RAYNOR®
GARAGE DOORS
Built to be worry free.™

RAYNOR® STYLEFORM™

SECTIONAL RAISED PANEL DOORS

When exterior appearance is a primary consideration, choose a stylish, raised-panel door from our attractive StyleForm series. StyleForm doors, equipped with heavy-duty, commercial-grade hardware, offer the perfect combination of beauty and reliability.

StyleForm OPTIMA

Designed for peak performance, this rugged, two-sided steel door is the perfect combination of beauty, strength and thermal efficiency. Available in the widest variety of colors, this door features an authentic woodgrain texture and a clean interior appearance to meet any design scheme.

StyleForm STANDARD

Available with optional polystyrene insulation, this durable, one-sided steel door is ideal when a classic, raised-panel appearance with a woodgrain texture is desired.

StyleForm BASIC

A simple solution for typical applications. This one-sided steel door features a pebblegrain texture and is available with optional polystyrene insulation.

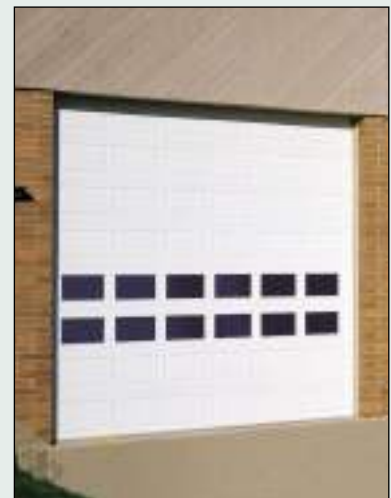

StyleForm STANDARD, raised-panel, white, with square windows

| Series MODEL | Max. Opening Width | Max. Opening Height | Construction | Surface Texture | Section Thickness | End/Center Stile Steel Thickness | Insulation (R-Value) | Thermal Break | Exterior Colors | Section Warranty |
|---|--------------------|---------------------|----------------------|------------------------------------|-------------------|----------------------------------|----------------------------|---------------|---|--|
| StyleForm OPTIMA (Commercial Decade ShowCase) | 18' | 14' | Steel Sandwich | Raised-Panel/Flush* (Woodgrain) | 2" | 18-Gauge/ N/A | Polystyrene (10.25) | Yes | White, Almond, ClayTone, Brown, Frost White, Beige, Sepia, BronzeTone | 1-Year (Any Rust) 5-Year (Delamination) |
| StyleForm STANDARD (Commercial Decade II) | 18' | 14' | Steel Pan (24-Gauge) | Raised-Panel (Woodgrain) | 2" | 18-Gauge/ 18-Gauge | Polystyrene-Optional (5.0) | No | White, Almond, ClayTone, Brown, BronzeTone | 1-Year (Any Rust) |
| StyleForm BASIC (Commercial Classic) | 14' | 14' | Steel Pan | Raised-Panel (Pebblegrain) | 2" | 18-Gauge/ 18-Gauge | Polystyrene-Optional (5.0) | No | White, Almond, ClayTone, Brown | 1-Year (Any Rust) |

*Flush available in White or Almond only.

WARRANTY StyleForm door sections carry a 1-year limited warranty against any rust and a 5-year limited warranty against delamination of the steel door skins from the insulating foam. See your local Raynor Dealer for complete details.

ONE-SIDED STEEL CONSTRUCTION

STYLEFORM STANDARD & BASIC



Optional insulation.

StyleForm STANDARD doors are available with energy-saving polystyrene insulation.



Durable construction.

StyleForm STANDARD and BASIC doors feature stainless steel riveted construction and roll-formed, tongue-and-groove meeting rails for maximum structural integrity.



Optional perimeter weatherseal.

Helps decrease energy costs and reduce air infiltration by sealing the top and sides of the door when closed.



Rugged hardware and springs.

Your StyleForm door comes packaged with the right combination of commercial-grade hardware, track and springs to match your door's size and application.



Woodgrain exterior.

StyleForm STANDARD doors feature an authentic woodgrain texture to complement any architectural style.



Decreased energy costs.

StyleForm doors help you reduce costs with a U-shaped, vinyl bottom weatherseal.



Pebblegrain exterior.

StyleForm BASIC doors feature a pebblegrain texture.

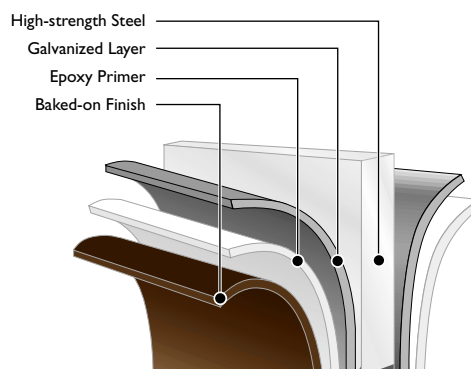

Built tough for superior performance, StyleForm STANDARD and BASIC doors feature hot-dipped galvanized, rust-resistant steel with a baked-on finish.

POWERHOIST™ OPERATORS



PowerHoist operators.

Raynor offers a full line of rugged PowerHoist operators. Trolley operators (top) are mounted overhead and suspended from the ceiling. Jackshaft operators (middle) are side-mounted and attached to the wall. Manual chain operation is also available.

Control options.

A variety of control stations, photoelectric eyes and remote activation devices are available.

STYLEFORM OPTIONS

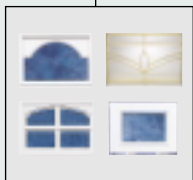

Choice of windows.

Choose from a variety of window styles, from clear glass to decorative leaded and beveled designs. Insulated glass is also available.

Counterbalance systems.

For reliable operation choose high-cycle torsion springs with 25,000, 50,000 or 100,000-cycle life or a weight counterbalance system.

Locks.

In applications where control and access are important, choose from a variety of locking options to help keep your building secure.

All StyleForm doors are available in White, Almond, ClayTone and Brown. For additional product color options, see below.

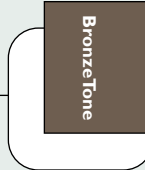
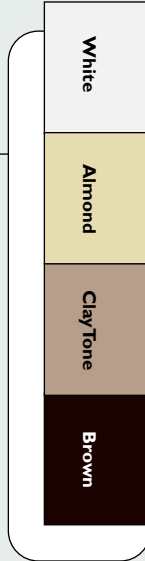

StyleForm OPTIMA and STANDARD doors are also available in BronzeTone.

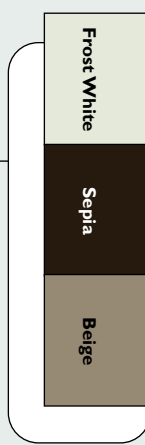

StyleForm OPTIMA doors may be upgraded to Frost White, Sepia or Beige. These colors feature the Kynar™ paint process, which provides extended UV protection against fading.

TWO-SIDED STEEL CONSTRUCTION

STYLEFORM OPTIMA

With its deeply embossed woodgrain texture, StyleForm OPTIMA adds curb appeal to any commercial building. And the two-sided steel design provides superior strength and added durability.

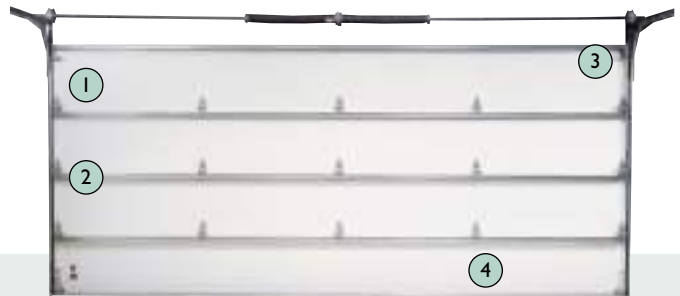

1

Insulation.

A core of polystyrene insulation is pressure-bonded between two steel skins for maximum energy savings and noise reduction.



4

Decreased energy costs.

StyleForm doors help you reduce energy costs with a U-shaped, vinyl bottom weatherseal.

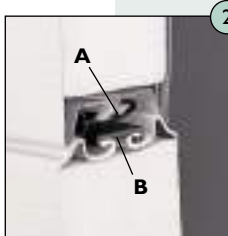

2

Reduced airflow.

A vinyl section joint seal (A) prevents airflow between sections, while a mechanically interlocked vinyl thermal barrier (B) prevents heat loss and eliminates metal contact between hot and cold surfaces.



Optional perimeter weatherseal.

Helps decrease energy costs and reduce air infiltration by sealing the top and sides of the door when closed.



3

Rugged hardware and springs.

Your StyleForm door comes packaged with the right combination of commercial-grade hardware, track and springs to match your door's size and application.

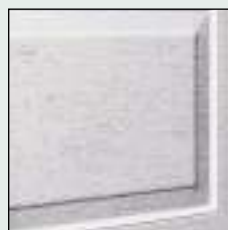

Woodgrain exterior.

StyleForm OPTIMA doors feature an authentic woodgrain texture to complement any architectural style.

Ruggedly designed to assure durable, long-lasting performance, StyleForm OPTIMA doors feature hot-dipped galvanized, rust-resistant steel with a baked-on finish.

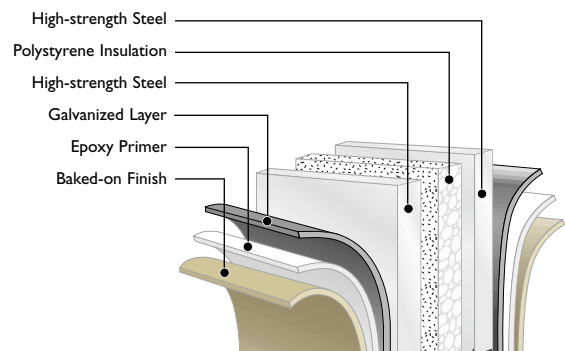



**Depend On Professional Installation
By Your Raynor Dealer**

When you select Raynor, you're not just getting a superior commercial door, you're getting professional door installation and service expertise.

Every Raynor door is installed by an experienced Raynor professional. And that means added benefits for you. Because it's done right the first time, your door will deliver performance and reliability from

the day it's installed. Your technician will check your door for everything from safety to performance to appearance.

Trust your Raynor door to someone who knows it better than anyone else—your professional Raynor Dealer. We have over 600 authorized dealers serving North America and over 50 countries worldwide.

Raynor also offers a full line of rolling service, fire and traffic doors as well as security grilles and counter shutters. See your Raynor Dealer or visit www.raynor.com for more information.



RAYNOR®
GARAGE DOORS

Built to be worry free.™

Raynor Worldwide P.O. Box 448, 1101 East River Road, Dixon, IL 61021-0448

CALL
1-800-4-RAYNOR

CLICK
www.raynor.com

FAX
1-815-288-7142

Exclusively Distributed By:



This information was as complete and factual as possible at the time it was printed. We do, however, reserve the right to make changes in product specifications and availability without notice. Features and options may be different in countries other than the United States. Product colors have been reproduced as well as possible with present commercial printing processes. For absolute accuracy in color matching, use actual product samples.