



THERMAL SECTIONAL DOORS

TC SERIES
THERMAL SECTIONAL DOORS



Raynor TC300, white, with oval windows

TC320

TC300

Visit us at : www.raynor.com
Call : 1-800-4-RAYNOR

TC SERIES

T H E R M A L S E C T I O N A L D O O R S

With a proven track record for thermal efficiency and extreme durability, Raynor TC Series is simply the best you can specify. With extruded polystyrene insulation thermally bonded between two steel skins, TC Series doors have an exceptional R-value of 17.05. And, its superior construction has made it the most specified sectional door on the market.

TC320

Designed for optimum strength and performance, this door's 20-gauge exterior steel skin and rugged hardware provides the ultimate in dependability. Raynor TC320 is ideal in applications where security and thermal protection are required.

TC300

The industry's benchmark for commercial sectional garage doors, this product provides unparalleled Raynor reliability and stability to meet or exceed the requirements of daily use. Raynor TC300 is offered with the widest selection of quality features and options for the most common product applications requiring strength, reliable operation and maximum thermal efficiency.



TC300, white, with full-view windows

Series MODEL	Max. Opening Width	Max. Opening Height	Construction	Surface Texture	Section Thickness	Exterior/ Interior Steel Thickness	End Stile Steel	Insulation (R-Value)	Thermal Break	Exterior Colors	Section Warranty
TC320	32'	24'	Steel Sandwich	Smooth	3"	20-Gauge (.035")/ 25-Gauge (.019")	14-Gauge	Polystyrene (17.05)	Yes	White	1-Year (Any Rust) 10-Year (Delamination)
TC300	32'	24'	Steel Sandwich	Stucco	3"	25-Gauge (.019")/ 25-Gauge (.019")	14-Gauge	Polystyrene (17.05)	Yes	White, Frost White, Dark Brown, Sepia, Beige	1-Year (Any Rust) 10-Year (Delamination)

WARRANTY TC Series door sections carry an exclusive 10-year delamination warranty (of the steel door skins from the insulation) and a standard 1-year limited warranty against any rust on all other door components. See your local Raynor Authorized Dealer for complete details.

MODEL OPTIONS AND UPGRADES



Choice of windows.

Select either 24" x 8" oval (shown) or full-view window (at left) in 36" x 14" or 42" x 14" sizes. Choose from a variety of insulated glass styles to suit any application.



Customized track and hardware systems.

Track systems are supplied to fit special clearances, inclines or contour applications. Hardware and track systems can be designed to fit any need.* Additional trussing is available for special windloading applications.



High-cycle counterbalance systems.

For reliable operation in high traffic areas, choose high-cycle torsion springs with 25,000, 50,000 or 100,000-cycle life. For reduced maintenance and ultra-smooth operation in heavy-use applications, choose a weight counterbalance system.



Pedestrian doors.

Pedestrian doors are designed for convenient entry and to help minimize energy loss.*



Jamb seal.

Helps to decrease energy costs and reduce air infiltration by sealing the side of the door when closed.



Removable center posts.

Carry-away and swing-up options are available for extra-wide openings. Ideal for agricultural or airplane hangar applications.



Locks.

In applications where control and access are important, choose from a variety of locking options to help keep your building secure.* Locks come in both inside and outside variations.



Carbon monoxide vent.

Allows you to channel fumes to the outside when door is closed. Available in a variety of sizes.

* Some options may be limited to door size or model. Contact your local Raynor Authorized Dealer regarding availability for your application.

COMMERCIAL OPERATORS



ControlHoist



PowerHoist



Commercial Operators

Raynor ControlHoist (with solid state logic board control) and PowerHoist operators are available in a variety of motor, voltage, and phase combinations for any commercial or industrial application. Contact your local Raynor Authorized Dealer to select the operator and accessories that are suited for your door's size and usage.

SPECIAL SIZES



Large opening sizes.

Because Raynor TC Series doors are so durable, we offer this product in a variety of sizes to accommodate large opening applications. For further information, contact your Raynor Authorized Dealer.

White

All TC Series doors are available in White. For additional product color options, see below.

Dark Brown

Frost White

Sepia

Beige

TC300 doors may be upgraded to Dark Brown, Frost White, Sepia or Beige. These colors feature the Kynar™ paint process, which provides extended UV protection against fading.

TC SERIES FEATURES

Every Raynor TC Series door is built for superior performance and includes the features listed below. For additional options, please see the inside spread.



Maximum thermal efficiency. 3" thick TC Series door sections are fully insulated with extruded polystyrene insulation.



Optimum energy savings. Flexible, EPDM rubber flap header seal reduces air infiltration and energy costs by sealing the top of the door against the header.



Reduced airflow. A vinyl section joint seal prevents airflow between sections. Our patented RollLock™ mechanically interlocked thermal barrier prevents heat loss and eliminates any metal-to-metal contact.



Rugged hardware and springs. Your TC Series door comes packaged with the right combination of long-lasting hardware, track and springs to precisely match your door's size and application.

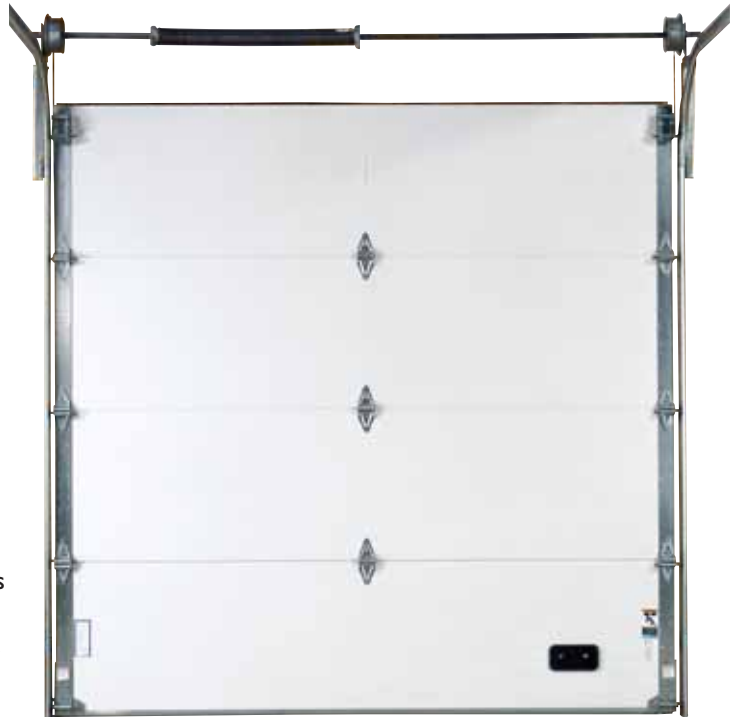

Decreased energy costs. TC Series doors help you reduce energy costs with a U-shaped, vinyl bottom weatherseal.

TC Series doors feature extruded polystyrene insulation thermally bonded between two hot-dipped galvanized, rust-resistant steel skins.

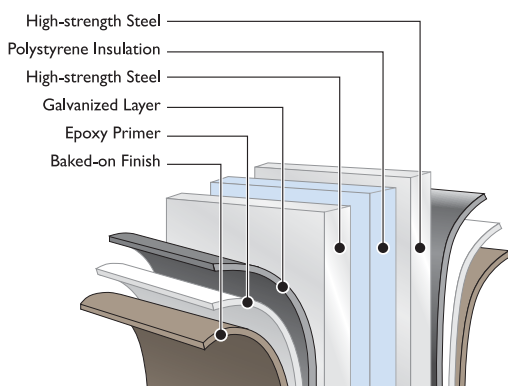

APPLICATION GUIDE

TC320 TC300

	TC320	TC300
Agricultural Buildings	●	●
Car Wash/Corrosive Environments	○	○
Commercial/Multi-Tenant	○	○
Fire Station/Ambulance	●	●
High Security	●	○
Large Opening Size	●	●
Service Station	●	●
Thermal Environments	●	●
Transit Facility/Truck Terminal	●	●
Underground Parking	○	○
Warehouse/Manufacturing	●	●

● Best Choice ○ Good Solution ○ Applicable

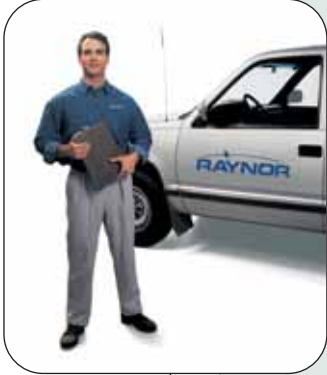

**Depend On Professional Installation
By Your Raynor Dealer**

When you select Raynor, you're not just getting a superior commercial door, you're getting professional door installation and service expertise.

Every Raynor door is installed by an experienced Raynor professional. And that means added benefits for you. Because it's done right the first time, your door will deliver performance and reliability from

the day it's installed. Your technician will check your door for everything from safety to performance to appearance.

Trust your Raynor door to someone who knows it better than anyone else—your professional Raynor Dealer. We have over 600 authorized dealers serving North America and over 50 countries worldwide.

Raynor offers a full line of commercial sectional doors. In addition, Raynor offers a full line of rolling service, fire and traffic doors, as well as security grilles and counter shutters. See your Raynor Authorized Dealer or visit www.raynor.com for more information.



P.O. Box 448, 1101 East River Road, Dixon, IL 61021

CLICK
www.raynor.com

CALL
1-800-4-RAYNOR

FAX
1-815-288-7142

Exclusively Distributed By:

This information was as complete and factual as possible at the time it was printed. We do, however, reserve the right to make changes in product specifications and availability without notice. Features and options may be different in countries other than the United States. Product colors have been reproduced as well as possible with present commercial printing processes. For absolute accuracy in color matching, use actual product samples.