



INNOVATIVE PRODUCTS, AFFORDABLE ALTERNATIVES: FLEXIBLE WALLS,

Since 1976, FlexBarrier Products has been serving thousands of commercial and industrial customers throughout the United States and the world with innovative and affordable products. Our products allow you to improve the safety, cleanliness, comfort, efficiency and energy savings in your work environment.

Just as our list of satisfied customers has grown over the years — along with ever-increasing demands for work-place solutions — so has our extensive line of products expanded, which now includes not only our original vinyl strip doors & curtains, but also an industry-best selection of quality-engineered flexible walls, security and bug screens, barriers and rooms.

Our comprehensive product line can be ordered in an almost unlimited array of individualized configurations, to meet your specific needs and budget.

And because we combine listening to our customers along with an ongoing program of research, testing and product development — FlexBarrier Products will continue to be the “people to see” for cutting edge solutions to your emerging future needs as well.

But it's not just our superior line of products that have made FlexBarrier Products an industry leader. It's also our nationwide network of hand-picked, dedicated distributors who are committed to providing an uncommonly high level of customer service. That means easy ordering and quick delivery ... expert advice and assistance in helping you design customized solutions ... courteous and responsive people who care ... and a sincere appreciation for your business and trust.





DOORS, BARRIERS AND ROOMS FOR THE WORK PLACE...



Whether you need to keep bugs at bay or manage a variety of temperatures, control dust or make your work environment safer and cleaner, FlexBarrier Products can answer your challenge with innovative, flexible and affordable products. Do like thousands of other discriminating business owners and managers who can't afford to make the wrong choice and look to FlexBarrier Products first. It's the right decision that'll put you in good company.

LOWER THE SCREEN ON BUGS

FLEXSCREEN ROLL-UP MODELS ARE THE EASY WAY TO KEEP BIRDS, FLIES,

Available with an electric motor, chain hoist or spring action, these doors offer fresh air, better light, increased security, employee comfort and improved productivity.

Packaging plants, food distribution warehouses, bottling plants, printing plants,

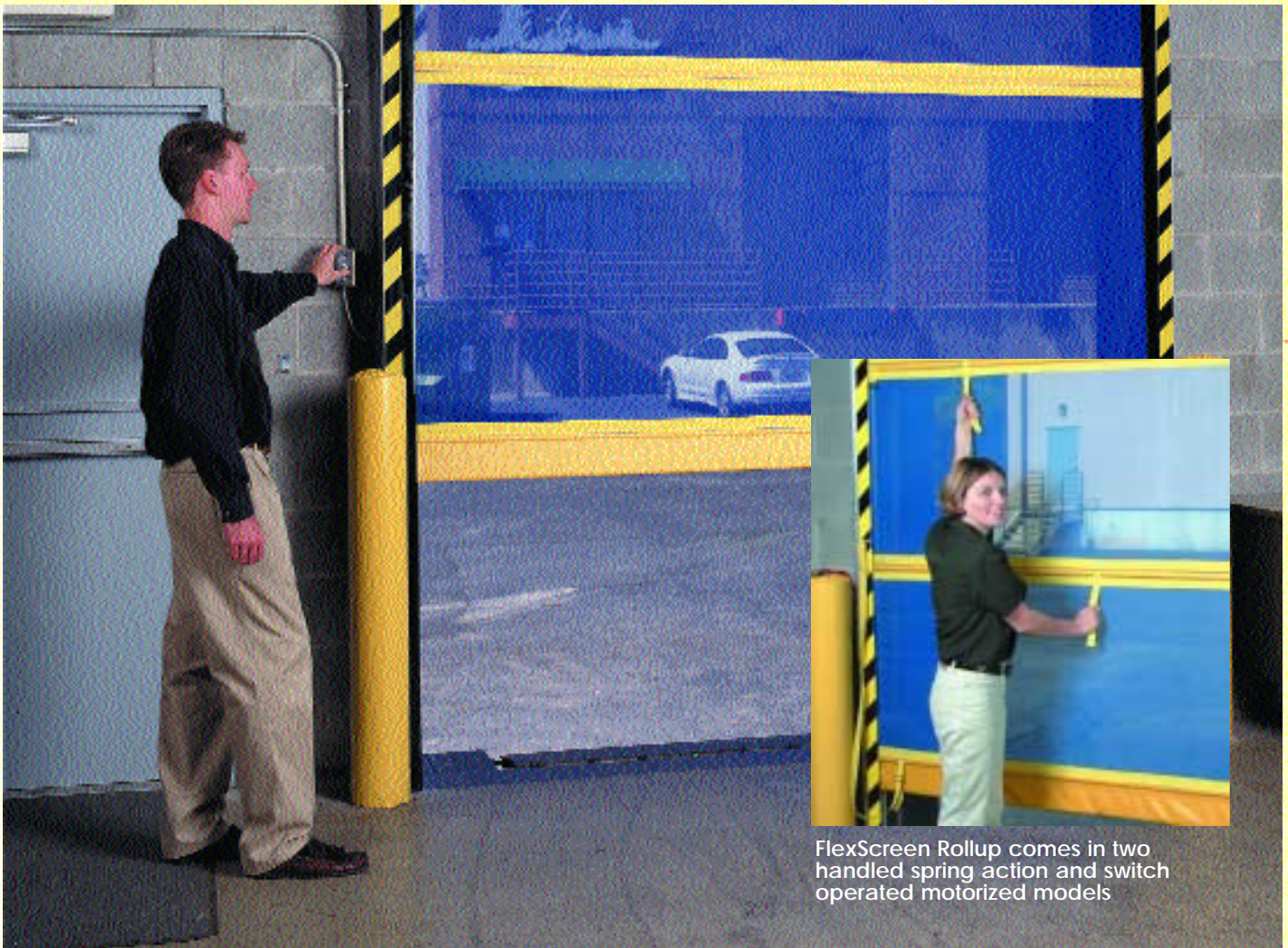

FlexScreen Rollup comes in two handled spring action and switch operated motorized models



Worried about Wind Load? Get the FlexBarrier Advantage.

- Horizontal 3/4" Fiberglass Stiffeners with sewn-in side webbing between to provide ultimate reinforcement
- Optional 4" deep track – extra depth to prevent blowouts
- 1" wide track – narrow guage for less give
- Available extra weight in bottom – sand or extra chain
- Optional lockable bottom bar for extra weight and secure hold down

MOTHS, MOSQUITOES, GNATS, WASPS AND OTHER INSECTS OUT!

paint manufacturing and other facilities across the country have discovered the benefits of FlexScreen. When you roll it up, it is out of the way, and it's always convenient and easy to handle. FlexScreen roll-up doors are held secure on the sides by a safety striped guide track with a flared top for easy operation. They can be ordered for inside-the-door standoff mounting, in-jamb mounting or face-of-wall mounting.



Vinyl Strip to seal the Guide Track along the edge

See Installation Options, Hardware and Accessories on Page 10.

The in-jamb mount has a vinyl flap to seal the top gap from insects.

A vinyl strip is attached to the guide track by hook and loop fastener on the inside standoff mounted version to seal out pests. A brush is attached to the bottom of the industrial door to seal at the top when the door is in the open position.

Installation on this version is made easy with adjustable guide track clips and slotted head plates.



Brush Seal covers gaps at top and on sides

Horizontal stiffeners provide for stability in windy conditions. The horizontal safety stripe allows workers to instantly check to make sure the screen is in the down position.

Screens are available in several colors.

Replacement screens, when needed, are easy to install.

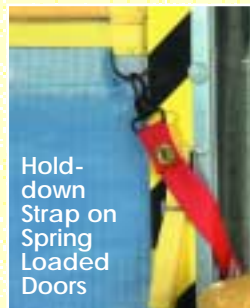

Hold-down Strap on Spring Loaded Doors

When FlexScreen Roll-up is down it keeps bugs and other pests out of warehouses, food processing plants, and production facilities while letting in sunlight and fresh air.

Quick Notes:

Quality

- Safety strips and stabilizer bars are sewn into the screen for visibility
- All models are designed and tested for durability
- Custom extruded aluminum track guides are striped for safety
- Mildew and fade resistant screen material used

Practicality

- Keeps out insects and birds, reduces dust and wind, improves sanitation
- Lets in fresh air and light
- Improves employee comfort and productivity
- Easy to order, install and maintain
- Increases security — a visual and physical barrier to reduce theft and pilferage



SLIDE THE SCREEN SHUT & Bug Out

KEEP OUT PESTS WITH THE ECONOMICAL FLEXSCREEN-SLIDE MODEL



Fresh air ventilation, sunlight, improved visibility and increased security are in! And so is employee comfort and improved productivity.

The easy to install FlexScreen slider can be attached under the header, or mounted to the inside wall with a bracket to allow the screen to be opened beyond the door frame and completely out of the doorway.

Both models feature a simple to use manual roller & track system that allows the FlexScreen to slide smoothly from side to side. Hook and loop fasteners and side seams reinforced with a steel bar completely seal the sides of the FlexScreen and also provide for easy opening and closing.

FlexScreen is made from durable, all-weather vinyl coated polyester which is fire retardant as well as mildew and UV resistant.

The inside wall mount model also incorporates a brush to seal the top against insects.

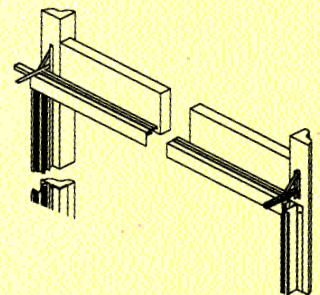

Quick Notes:

Quality



- Safety strips sewn into curtain for screen visibility
- Brush made from durable nylon fibers; brush hardware is extruded aluminum
- Nylon rollers; galvanized track; coated steel wall brackets.
- Vertical stiffeners, velcro and magnets are used to tightly seal the sides and allow for easy opening.

Practicality

- Keeps out insects & birds, reduces dust & wind, improves sanitation
- Lets in fresh air and light
- Improves employee comfort and productivity
- Economical to buy and maintain
- Easy to install
- Increases security — a visual and physical barrier to reduce theft & pilferage
- Can be custom ordered to fit almost any opening

Use the FlexScreen-Slide at Loading Docks, Garages, Waste Areas and Food Processing Facilities. Keep out birds and bugs and let in sunlight and fresh air!

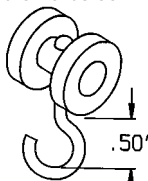
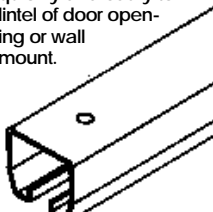
SLIDE FLEXSCREEN INSTALLATION & ACCESSORY HARDWARE

<p>Hook Rollers are hooks mounted on an axle with two nylon wheels. This provides for easy opening and closing of the FlexScreen.</p> 	<p>Standard Track is straight roller track formed from 16 gauge hot dipped galvanized steel for durability and long life. Attaches quickly and easily to lintel of door opening or wall mount.</p> 	<p>Side Wall Brackets are coated steel angle for years of trouble-free service and are used to attach inside wall mounting.</p> 	<p>Wall Mount Brush is made from nylon fibers. It's used with inside wall mount to seal the top of the FlexScreen - keeping out insects, dust and other contaminants. Extends from top of track over to wall.</p> 
---	---	---	---

OR FILL THE OPENING WITH A SCREEN To DE-BUG



HAND-HELD, HAND-INSTALLED, FRAMED FLEXSCREEN-STATIONARY



Brush Seal along frame edges. Spring latch holds the screen securely in place

FlexScreen-Stationary portable framed screen keeps out pests on loading dock openings where limited or no access is needed, and it lets in light and fresh air!

Vinyl encapsulated woven polyester mesh on a tubular aluminum frame snaps into loading dock openings between the door jamb. Keep out pests, improve security and provide more ventilation and sunlight for employee comfort and productivity.

Quick Notes:

Quality

- 1 inch aluminum tubular frame with crossmember stiffeners for stability and durability
- Brush around the outside of frame seals around the edges even on non-square openings. Hem pocket at the bottom adapts for uneven floor
- Sturdy spring pin locks (4) hold the frame in the jamb

Practicality

- Keeps out insects & birds, reduces dust & wind, improves sanitation
- Lets in fresh air and light
- Improves employee comfort and productivity
- Economical to buy and maintain
- Easy to install
- Increases security — a visual and physical barrier to reduce theft & pilferage
- Can be custom ordered to fit almost any opening

Your SENTRY

ON THE LOADING DOCK

FLEXGUARD CHAIN MESH SECURITY SCREEN DOORS THAT ROLL-UP AND



Steel side wall brackets allow FlexGuard to be used with existing dock doors.

OWN TO KEEP OUT BIRDS, BUGS AND BAD GUYS

Alleviate trespassing, help prevent theft and pilferage, and protect warehouse personnel while letting in fresh air and light with strong chain mesh and our proven structural approach – the same used on our popular FlexScreen.

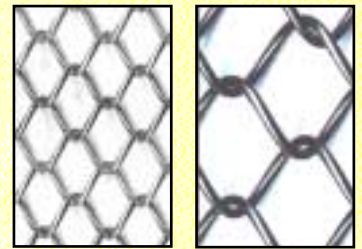

Standard Stainless Steel or Aluminum Mesh—actual size: 1/4" (left) and 1/2" (right)

FlexGuard Chain Mesh Security Doors are available in various aluminum or stainless steel mesh sizes. And the security doors are easy to install in a variety of models and mounting options.



(Above) Metal sheeting covers the side of the guide tracks to provide a secure seal.

(Right) Kick-latch at the bottom of FlexGuard doors allow lockdown. An automatic kill switch eliminates motor damage.



Quick Notes:

Flexibility

- Easy open - intube motor for smaller openings, chain-hoist for low-usage openings, and external motor for larger openings
- Choice of mesh sizes and material - aluminum or stainless steel
- Three mounting styles - in-jamb, face-of-wall, and inside stand-off
- Can be custom ordered to fit almost any opening

Practicality

- Lock-down system
- Simplistic design - proven structural system
- Horizontal stiffeners add strength and security
- Lets in fresh air and light
- Improves employee comfort and productivity
- Economical to buy and maintain
- Easy to install
- Increases security — a visual and physical barrier to reduce theft & pilferage

See Installation Options, Hardware and Accessories on Page 10.



Vinyl Doors

ON A ROLL

FLEXVRD COVERS & SEALS TO CONTROL DUST AND TEMPERATURES

FlexVRD is an economical vinyl covering for interior or exterior door openings to seal out dust and control temperatures. The clear panel provides a safe and easy view of what's on the other side. Choose a slow/ medium speed motor or a manual chain hoist to move door up and down and provide years of easy access.

Quick Notes:

Flexibility

- Easy open - intube motor for smaller openings, chain-hoist for low-usage openings, and external motor for larger openings
- Choice of colors in 22oz or 40oz. vinyl material with a clear view panel
- Three mounting styles - in-jamb, face-of-wall, and inside stand-off
- Can be custom ordered to fit almost any opening

Practicality

- Fire resistant, waterproof, washable, rip resistant and rot and mildew resistant
- Easy to install — 3 mounting styles: in-jamb, inside standoff, face of wall
- Horizontal stiffeners add strength and security
- Increased energy savings and employee efficiency
- Uses proven FlexScreen design and hardware
- Increases security — a visual and physical barrier to reduce theft & pilferage



Roll-up Door Accessories & OPTIONS

FLEXSCREEN, FLEXGUARD AND FLEXVRD HARDWARE

These items are available as replacement parts or options. Some are accessories that can be added to the standard package on each product.

Accessories:



FlexIC (Interior Cover) is an attractive faceplate as well as a protective valance for the door roll.

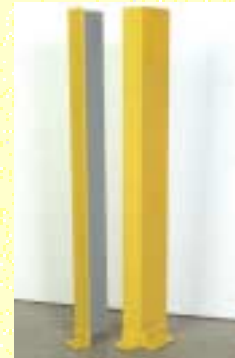

FlexTG (Track Guard) provides tough, attractive protection for vulnerable door tracks. Simple installation - FlexTG anchors directly to the floor through pre-drilled holes with anchors. Made from 1/4" steel plate to withstand maximum impact. FlexTG is available in a 48" height.



FlexEC (Exterior Cover) is an attractive and protective faceplate for exterior use. The ends are sealed to provide an extra level of protection for the door roll. FlexIC and EC are both made of heavy gauge steel.

Replacement Brush Seals



Brush Seal can be ordered in various lengths as a replacement part to seal sides, top and bottom of various products

Guide Track Options:



Safety Striped Guide Tracks in two sizes

Mounting Options:

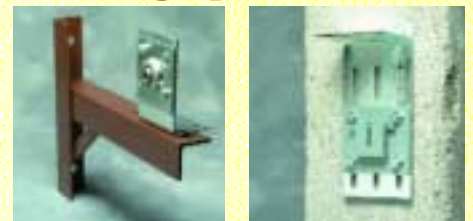

Inside Wall Bracket

In-Jamb Mount

Motorized, Spring and Manual Options:

Motorized This model comes with an In-tube motor (ITM) or an External Continuous Duty Motor (ECD) designed for frequent opening and closing. (ITM not recommended for opening more than 8 times per hour.) The door is operated from a rocker switch which is provided.



ITM



ECD

Both motors have up and down limit switches. The ECD model has an emergency chain hoist.

Spring Tube Model (STM) This model rolls on a spring action tube and has two handles to manually pull screen into the down position. Two latches are provided to hold the door securely down. The assembly comes heavily lubricated.



STM

Chain Hoist Model (CHM) This model operates like a traditional chain hoist roll-up loading dock door.



CHM



EASY come EASY GO!

DURABLE RIBBED VINYL STRIPS AND UNIQUE HINGE-LIKE HARDWARE MAKE

With a unique mounting system FlexStrip EZ Access doors and curtains are more durable and easier to install. Two people can handle installation in less than an hour with a few simple tools. And the superior design makes individual strip replacement, if needed, a snap. FlexStrip support tube and swivel brackets are zinc plated steel for rust free strength and durability. Plus this tube and bracket system virtually eliminates strip fatigue (cracking) at the top for longer life expectancy.

Quick Notes:

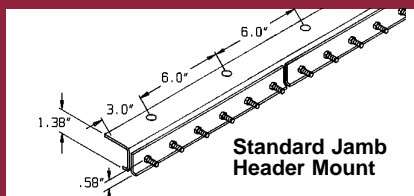

Standard Jamb Header Mount

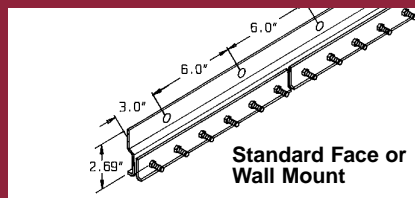

Standard Face or Wall Mount

For interior doors, loading dock receiving doors, welding areas, refrigerated areas, irregular openings, and even trucks, FlexStrip doors and curtains offer unmatched advantages and benefits.

Economy

- Less expensive than conventional doors
- No motors or moving parts to break
- Replace strips only where needed
- Pay back in as little as 6 months

Efficiency

- Reduce heat loss by up to 90%
- KWH's reduced by 40-60%
- No motors to use energy

Convenience

- Gain full use of opening
- Transparent to let in natural sunlight
- Safe - allows workers to see approaching traffic through the opening
- Easy access from either direction
- Use only that portion of the opening needed when passing through
- Warmer, quieter, cleaner & safer than other doors. Easier to install and maintain, too

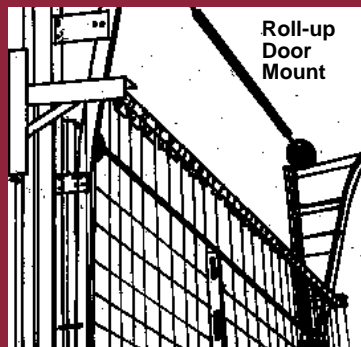

Roll-up Door Mount



With unique FlexStrip door hardware, ribbed vinyl strips can be installed or replaced easily with simple tools.

Universal U-Mount is used to mount the support tube and swivel bracket hardware to either under the header or the face of the wall.

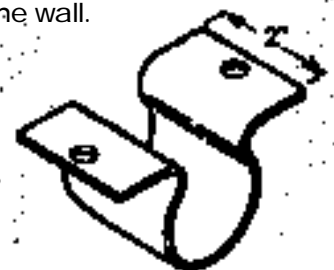

STRIP TYPE	APPLICATIONS
Standard	Ideally suited for most interior/exterior applications with low to moderate traffic. UV property reduces yellowing. Withstands temperatures from 0 to 150.
Ribbed	Interior/exterior with moderate to heavy traffic, especially where heavy material handling vehicles operated. Withstands temperatures from 0 to 150. Resists scratching - extended product life.
USDA/Low Temp	For refrigerated areas, or other areas where food handling is involved. For temperatures from -40 to 100. Recommended for interior use only. Available in standard and ribbed type material.

LEXSTRIP DOORS SOME OF THE LONGEST LASTING IN THE INDUSTRY.



FlexBarrier
PRODUCTS, INC.

THE Great Divider

DIVIDE AND CONQUER INSECTS, DUST, WIND, MOISTURE, FUMES, AND AIR

FlexCurtain/Wall vinyl walls are the perfect solution when you need a wall to compartmentalize your operations. FlexCurtain/Wall vinyl walls are ideal for manufacturing plants, warehouses, food preparation areas, greenhouses, hangars — in fact anywhere you need a wall at low cost that is non-permanent and flexible.

Quick Notes:

Economy

- Less expensive than a permanent wall, and less time consuming and expensive to install

Flexibility

- Easy to relocate — not a permanent wall. Move it whenever and wherever it's needed
- Easy to open — can be moved out of the way like a curtain
- Easy to install — comes in sections no wider than 20' which can be attached to one another with either grommets or velcro and hung from steel cable with grommets and S-hooks; also can be installed with roller track with rollers

Quality

- Reinforced PVC coated vinyl — 14 - 40 oz. per square yard. Resists mildew, flame and acid
- Available in solid colors or a beige translucent style (our most popular)
- All edges are folded and sewn before we attach grommets or velcro. If chain is required at the bottom, we sew it in during production

Options

- Bottom — sew plain hem, chain for weight, grommets or pocket for pipe
- Top — grommets or plain hem
- Sides — plain hems, grommets or velcro
- Grommets are on 12" centers



Cable & S-hook Installation

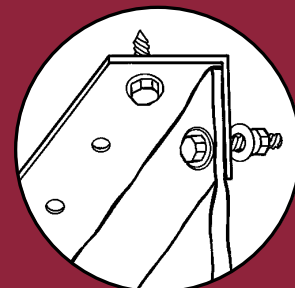

Angle Iron Installation

FLEXCURTAIN/WALL ACCESSORY HARDWARE

Standard Track is straight roller track formed from 16 gauge hot dipped galvanized steel. Standard straight track sections may be joined to span wide areas or joined with curved track to turn corners.

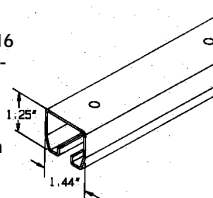

Hook Rollers are hooks mounted on an axle with two nylon or steel ballbearing wheels. This provides free rolling flexibility allowing the material to gather like a shower curtain.

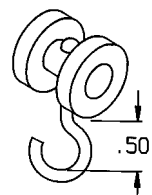

Hem Chain placed in the bottom hem provides weighted stability where FlexCurtain/Wall is installed like a curtain.

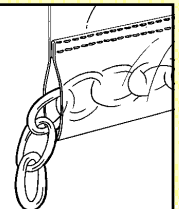

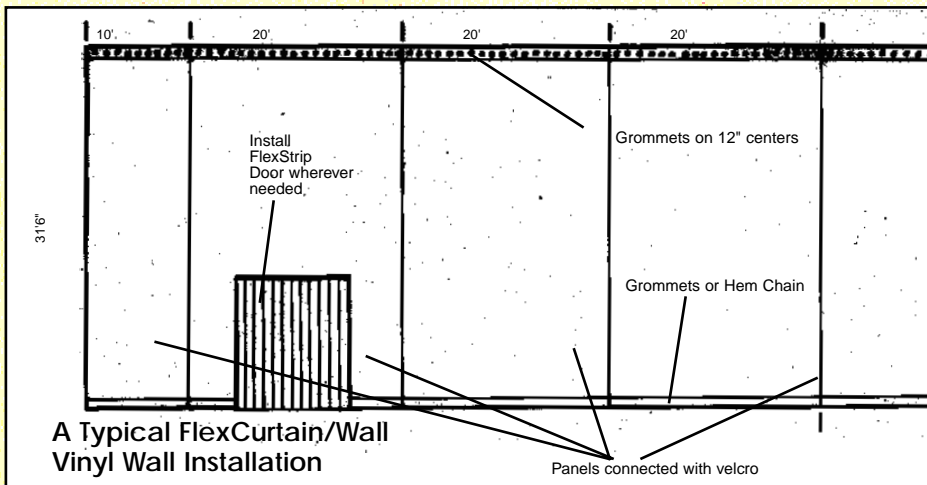

ORNE PARTICLES — WITH FLEXCURTAIN/WALL FOR LARGE SPACES



Cold FRONT

FLEXTHERM WALL™ DIVIDERS. A BARRIER FOR TEMPERATURE CONTROL IN

FlexTherm Walls are the perfect solution when you want to have the ability to change the sizes of your rooms quickly, easily and with low cost. They also will prevent condensation build-up on the warm side of your barrier wall.



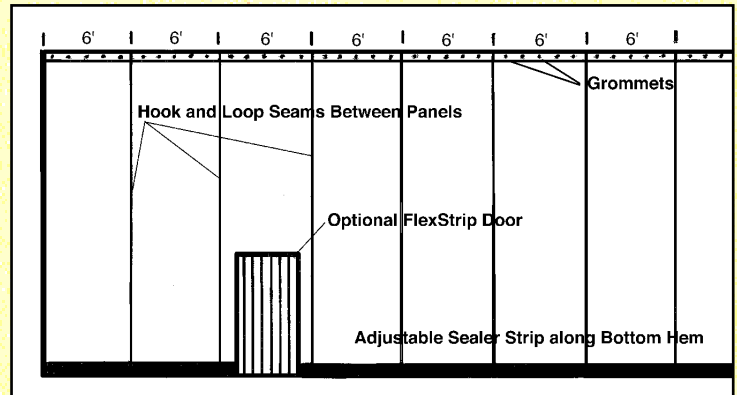

COOLERS AND FREEZERS.



Panels are 6' wide with two outer layers of reinforced vinyl. Between the outer layers is a combination of foil and bubble to reflect and isolate the temperatures. Hook and loop fasteners on the side edges seal the panels together to create a solid wall. The bottom edge is folded over and stitched to seal against moisture. A 4" strip of hook is added to the bottom — this allows a piece of 8" adjustable material with a loop strip to be attached and adjusted to seal at the floor.



Quick Notes:

Quality

- All edges are folded under — this reduces moisture build-up
- Sewing is double-stitched with moisture-resistant thread
- Two layers of reinforced coated PVC flame-retardant material are used as the outer layer
- Repairs are easy with a patch kit if the fabric is torn
- Cleaning is simple by using a mild detergent and water

Easy Installation

- Attach to angle iron either at the roof deck or under the joist

Flexibility

- Panels may be moved to reconfigure your room to meet seasonal needs
- You may add or subtract panels as needed
- It is lightweight to make moving the panels that much easier

Economy

- Initial installation is easy and quick — which saves money on labor
- if the cooler/freezer space needs to be reconfigured it is easy to move, and add or subtract panels

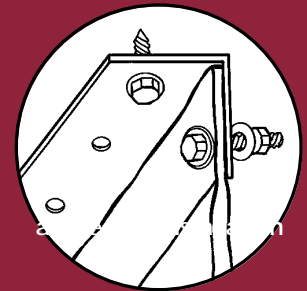

- **6' wide sections**
- **hook and loop fasteners on side edges**
- **grommets at top**
- **lightweight panels**
- **outer layers made of reinforced vinyl material**
- **easy to clean and patch**
- **installation quick and easy**
- **adjustable sealed edge at bottom**



The ADVANTAGES of FlexRoom ARE CLEAR!

FLEXROOM SYSTEMS OFFER THE ULTIMATE IN FLEXIBILITY... AT A FRACTION

Introducing the FlexRoom System from FlexBarrier—the flexible and versatile answer for in-plant offices, dust-free storage areas, computer terminal & printer rooms, welding areas, workrooms, breakrooms and more.

FlexRooms can be custom ordered in any size to fit your current and future requirements. Size up or size down overnight as your changing needs dictate. Or take it down and move it to another location in minutes using your own people. It's safe, noncombustible and easy to maintain.

And FlexRoom setup and installation is a snap! Easy to handle vinyl walls attach quickly, smoothly and securely to sturdy support bars with hook and loop fastener. No need for hammer and nails, paint brushes, building permits, or outside contractors!



FlexRooms can also be made with solid or transparent color panels like this storeroom.



Sturdy Corner Support Assembly

Rust-free anodized aluminum tubing reinforced with 45° angle brackets at the corners provides superior stability. The components are easily put together using a wrench, pliers, and screwdriver.

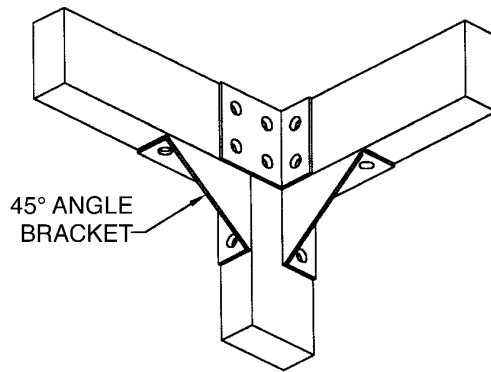

THE COST OF OTHER SYSTEMS!

The flexibility of the FlexRoom System means that the possibilities are limited only by your imagination. You may have an application for FlexRoom that we haven't even considered. Our representatives will be pleased to assist you in custom designing a room to fit your particular needs.

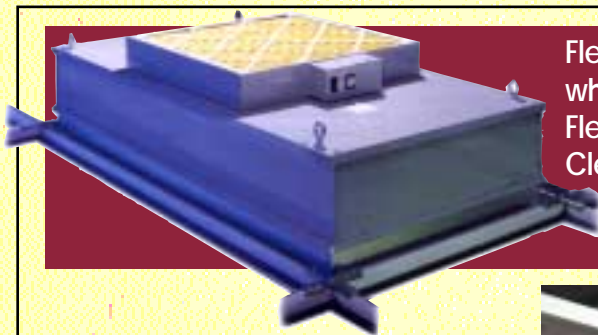

FlexBarrier offers HEPA filters which can be mounted on FlexRoom's ceiling grid for Clean Rooms.

Create an Effective Cleanroom with FlexRoom's Available Hardware

Our optional heavy-duty drop ceiling grid supports HEPA filters, ceiling panels and lighting for clean rooms while providing for a sleek exterior appearance. With the heavy-duty grid system and HEPA filters, cleanrooms can be rated from Class 100,000 down to Class 5000. The Class rating is in direct proportion to the cubic feet size of the FlexRoom and the number of air changes per hour.



Quick Notes:

Flexibility

- Uses include in-plant offices, storage areas, computer equipment rooms, welding areas, breakrooms and more!
- Available in clear, translucent, UV welder's material and solid color panels.
- Easy installation due to modular design. Anchoring to the floor is optional. Add or interchange panels easily — or move to another location — for other applications. Additional standardized panels can be ordered at any time.

Quality

- Walls are made of industrial grade vinyl for years of service.
- Aluminum tube is heavy duty for rock-solid stability and rust prevention.
- Tough corner brackets insure sturdy support.
- Special hook and loop fastener adheres smoothly and securely to aluminum frame and vinyl walls.

Economy

- Inexpensive front end costs give maximum value and utility for less than conventional systems
- Quick and easy installation. No installation crews or outside contractors needed

Service

- FlexBarrier representatives will work closely with you to customize FlexRoom to fit your application.
- Modular components and attentive service allow fast shipment to fit your deadlines.
- All hook and loop fastener applied at factory.



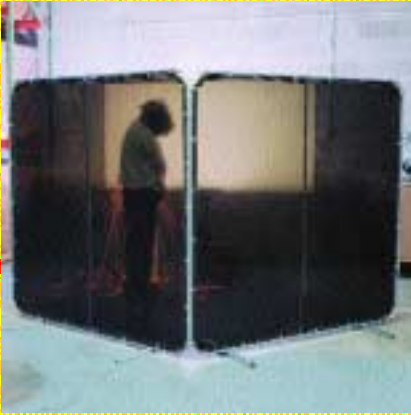

NO Sparking ZONE

FlexSpark vinyl protective panels prevent passage of sparks, heat, fumes, particulate matter, dust, and chemical spray in welding, grinding and machine areas. These transparent partitions are moveable for maximum flexibility and tinted to insure eye safety outside of the work area.

- Fire and chemical resistant — screens out UV Rays
- Modular, lightweight, and portable
- Economical and durable
- Wheels may be added for mobility
- Custom made to any size



REAL Swingers

FlexVision is a 180 degree swing door for frequently used passages to coolers, freezers, food preparation areas, and manufacturing plants. The vinyl doors provide maximum visibility and minimal temperature loss without disturbing or damaging items being carried by employees.

- Available in various types and colors of vinyl and two hardware types
- Easy to install — preassembled
- Increased energy savings and employee efficiency
- Can be used in many different applications



Innovative Products, Affordable Alternatives: Flexible Walls, Doors, Barriers and Rooms for the Work Place

P.O. Box 2612
Norcross, Georgia 30091
FAX 888-884-9667

1-800-277-3539

Visit us on the WEB: www.flexbarrier.com

